



**OWNER'S MANUAL
WARRANTY INFORMATION AND
INSTALLATION INSTRUCTIONS**

**PRODIGY
GAS STORAGE WATER HEATER**

**330TN, 360TN
330TL, 360TL**

FOR ADVICE, REPAIRS AND FAST SERVICE:

**1300 365 115 (AUSTRALIA)
0800 729 389 (NEW ZEALAND)**

CONTENTS

APPLIANCE & SERVICE DETAILS	3
INSTALLATION DETAILS	4
OPERATING INSTRUCTIONS	11
SERVICE INFORMATION	13
WARRANTY	16
SPECIFICATIONS	18

WELCOME TO DUX HOT WATER

Your decision to purchase a Dux water heater will reward you for many years to come.

Since 1915, the Dux range has seen continuous research and development, resulting in many breakthroughs in the efficiency, reliability and longevity of hot water systems.

Dux water heaters are manufactured in Australia in a state-of-the-art facility, using a Quality Endorsed Company production system.

This is your assurance that you have purchased the highest quality water heater available, one that will provide continuous hot water for all your needs - safely, economically, and for many years to come.

FEATURES OF YOUR DUX GAS WATER HEATER

- Advanced heating design for better reliability.
- High efficiency design.
- Adjustable Thermostat - allows you to adjust water temperature, saving energy costs during warmer months of the year.

WARRANTY RETURN CARD

Enclosed you will find a warranty card - please fill in the details and return immediately.
This will ensure prompt service under warranty, if required.
See page 16 for terms of warranty.

Privacy Act Amendment 2000; If and whenever warranty service is required, your personal details will only be given to an
Authorised Dux Service Agent for the express purpose of carrying out the arranged warranty service work agreed by you the client
and Dux Manufacturing Limited.

APPLIANCE DETAILS

For future convenience, would you kindly fill in the following details and retain with your
original invoice for your own records.

Owner's Details:

Surname:..... Given Name(s):.....

Address:.....

Town/Suburb:.....

State/Territory:..... Postcode:.....

Date of Purchase:..... Purchased From:.....

Model:..... Serial Number:.....

Date of Manufacture:.....

Gas Type: (✓) Natural Gas LPG

(Details on Data Plate on water heater)

Installer's Details:

Date of Installation:..... Installer's Name:.....

Address:.....

Installer's Signature:.....

SERVICE DETAILS

Date of Service:..... Serviced By:.....

Work Carried Out:.....

.....

.....

Signature of Service Agent:.....

INSTALLATION DETAILS

This water heater must be installed by a licensed tradesperson, and in accordance with:

- AS/NZS 3500.4 - "Plumbing and Drainage Code: Heated water services".
- AS5601 / AG601 "Gas Installations".
- Local authority regulations.

Note: *This water heater is not suitable for pool heating.*

This water heater is designed for direct connection to water supply pressures up to 1100kPa. Where the mains pressure can exceed or fluctuate beyond 1100kPa, a pressure limiting device (complying with AS1357) must be fitted in the cold water inlet supply. This device must be installed after the isolating valve and set at or below 1100kPa.

Note: *Ensure that the water heater is suitable for the available gas supply (LPG, Natural Gas, etc.).*

In the interests of energy conservation it is recommended that this water heater be fitted with an expansion control valve (a type of pressure relief valve) on the cold water supply line between the non return valve and the water heater (refer to Installation Diagram, Figure 2). This device will ensure the water discharge due to heating expansion is of cold water rather than hot water that contains "consumed (and paid for) energy". Other means of optimising the energy efficiency of your water heater include the fitting of AA or AAA Rated shower roses and adjusting the unit's thermostat to suit the season and usage patterns.

CAUTION: This water heater delivers hot water at temperatures exceeding 50°C. Refer to AS/NZS3500 and local regulations regarding the need for additional hot water delivery temperature control.

LOCATION

The water heater should be located as close as possible to the most frequently used hot water outlet. Adequate access must be made for service to the burner, gas control, relief valve and anode.

Note: *All models are equipped with two sacrificial anodes, accessible by removing the top cover.*

OUTDOOR Installation ONLY

The water heater should be installed OUTDOORS with the minimum clearances as shown in Figure 1. The water heater should be installed on a level, fireproof plinth at least 50mm above the surrounding ground level. Position the two wall brackets 25 mm below the lip of the lid and secure them so that they are protruding approximately 10mm beyond the back of the heater. Position the unit in place and secure the brackets to the wall (as per Figure 1).

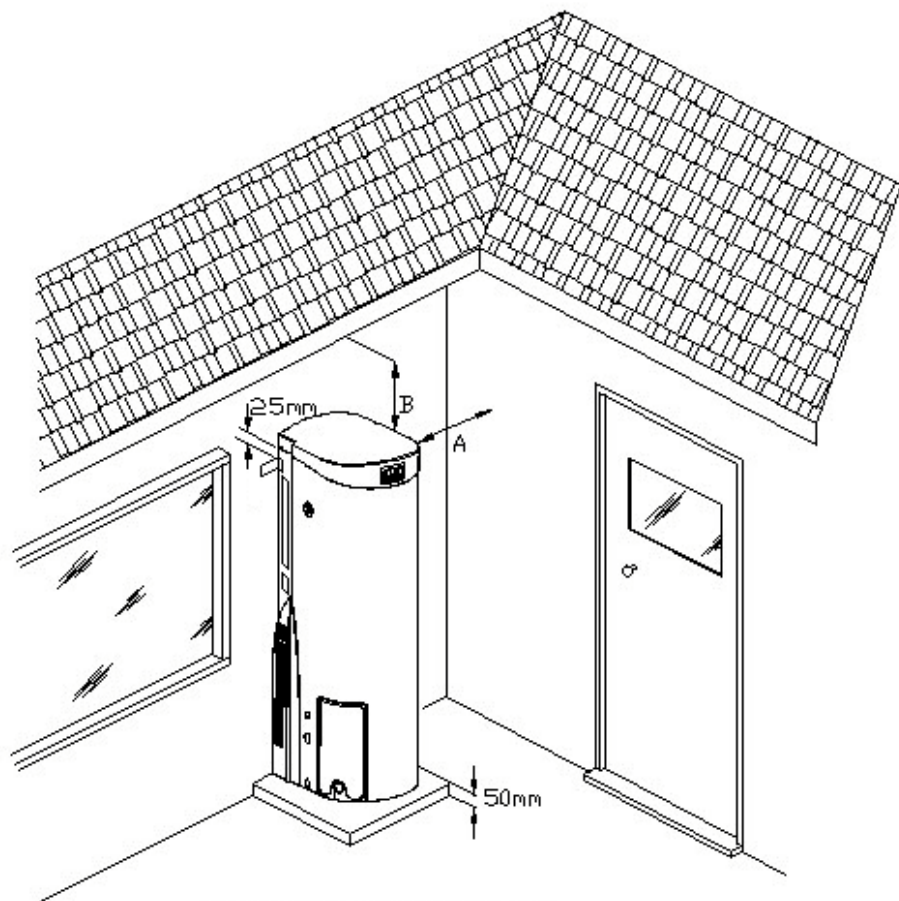

A = 500mm min, B = 300mm min.
for further details, refer to AG601.

Figure 1: Clearances Required for Outdoor Installation

COLD WATER CONNECTION

An approved isolating valve, non-return valve, line strainer (optional but recommended) and union must be fitted between the supply main and the RP $\frac{3}{4}$ /20 socket in the water heater. All fittings must be approved by the relevant Authority. See Figure 2 for details.

Note for S.A. and W.A.: It is a state requirement that a pressure relief valve be fitted on the cold water supply line between the non-return valve and the water heater (see Figure 2).

Warning: *A separate drain line must be used for this relief valve. It is not permitted to couple drain lines from relief valves into a single common drain line.*

HOT WATER CONNECTION

A relief valve is supplied to fit into the RP $\frac{1}{2}$ /15 adaptor socket. The hot water drain pipe and relief drain line to be installed as per Figure 2. For the most economical operation of the water heater, it is recommended that all hot water lines are insulated for the first 1.5 to 2 metres of hot water line from the heater.

PRESSURE AND TEMPERATURE RELIEF VALVE

The Pressure and Temperature Relief Valve (rated at 1400kPa) is supplied loose with the water heater. The valve must be installed into the top socket marked "RELIEF VALVE".

GAS CONNECTION

Gas piping should be connected to the side of the case (see Figure 2). The fitting provided is an RC $\frac{1}{2}$ /15 socket. A union connection should be used. Pipe sizes should be in accordance with AS5601 / AG601.

A second spanner should be used on the brass fitting provided to ensure that no rotation of that fitting can occur.

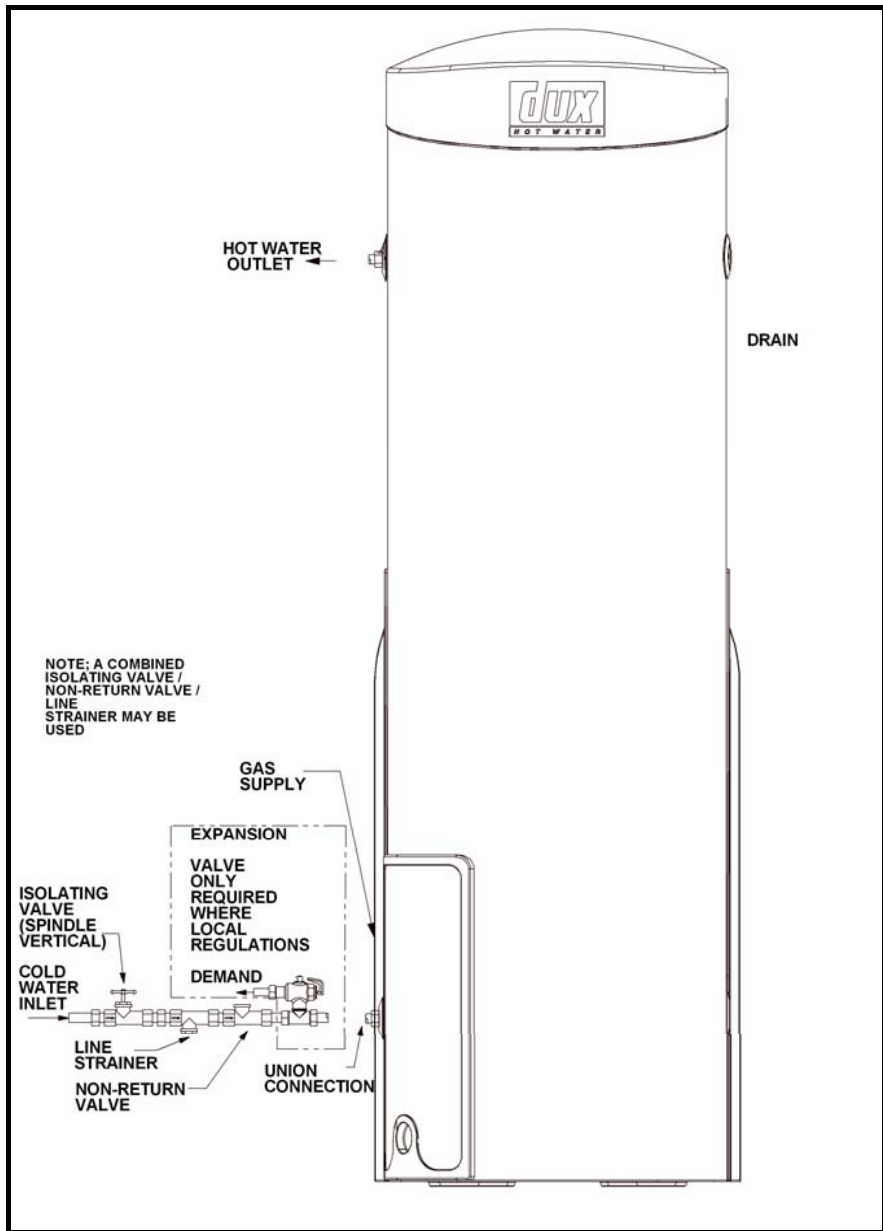

Figure 2: Hot & Cold Water Connections

WATER QUALITY

Your Dux water heater has been manufactured to suit water conditions of most Australian metropolitan supplies. Please note that harsh water supplies can have a detrimental effect on the water heater and its life expectancy. If you are unsure about your water quality you can obtain information from your local water supply authority.

The water heater is designed for use in areas where the Total Dissolved Solids (TDS) content of the water supply is less than 2500 mg/L.

In areas where the TDS exceeds 600mg/L it is possible that the magnesium alloy anodes (supplied in the heater and colour coded orange) may become over reactive. To alleviate this, the magnesium alloy anodes should be replaced with aluminium alloy anodes (colour coded blue), available from your local Dux supplier. Remove the lid, which is secured by two (2) screws at the rear and a clipping arrangement at the front, to gain access to the anode sockets.

Water can also be very corrosive. The measure of this is the Saturation Index. If the Saturation Index is greater than 0.40, an expansion control valve should be fitted and where the index is greater than 0.80, the water heater installed should be a Hard Water Model. Please consult our Service Department for advice if required.

TESTING THE WATER HEATER

Test operation by lighting the water heater (see *Operating Instructions*). Check that the test point pressure of water heater complies with the Data Plate. Check that the pilot flame plays on the last 4mm of the thermocouple. If necessary, adjust accordingly by following the instructions under “*Commissioning Adjustments*” in *Service Information* (Page 13).

Note: *Instruct owner in water heater operation before leaving.*

WARNING!

It is essential for the safe operation of this gas heater that clothing or any other flammable material should not be placed against or on top of the water heater. In addition, do not store flammable or corrosive materials, such as dry cleaning fluids, pool chemicals, etc., in close proximity to the heater.

The use of aerosol sprays in the vicinity of the heater should be avoided. The propellant gases used in these devices, e.g. fly-spray, hair-spray and laundry aids, can break down in the flames of the burner and produce corrosive agents.

CAUTION!

If this water heater is left in an operating condition and unused for two weeks or more, a quantity of hydrogen (which is highly flammable) may accumulate in the top of the water cylinder. To dissipate this gas safely it is recommended that a hot tap be turned on for several minutes at a sink, basin or bath, but not a dishwasher, clothes washer or other appliance. During this procedure there must be no smoking, open flame or any other electrical appliance operating nearby. If hydrogen is discharged through the tap it will probably make an unusual sound as with air escaping.

SAFETY INFORMATION:

The appliance is not intended for use by young children or infirm persons without supervision. Young children should be supervised to ensure that they do not play with the appliance.

WARNING:

For safe performance this water heater is fitted with:

1. Thermostat.
2. Over-temperature energy cut-out.
3. Combination pressure and temperature operated relief valve.

These devices must not be tampered with or removed.

The water heater must not be operated unless each of these devices is fitted and in working order.

Relief valves should be checked for adequate performance or replaced at intervals not exceeding 5 years, or less in areas where there is a high incidence of water deposits. The lever on the relief valve must be pulled to operate the valve at least once every 6 months. Failure to operate the relief valve easing gear at least once every six (6) months may result in the water heater exploding.

IMPORTANT

The relief valve and its drain outlet pipe must not be sealed or blocked. It is normal for the valve to overflow during a heating cycle.

WARNING!

GAS FITTER:

This water heater should be checked on installation and the test point pressure set in accordance with that marked on Data Plate (see *"Testing the Water Heater"* in the Installation Details).

Failure to accurately set the pressure can result in damage to the water heater, and automatically cancels the Manufacturer's Warranty. This water heater is to be installed only by an Authorised Person. ***This water heater must be installed on a fire-proof base (see Figure 1).***

USER:

DO NOT place articles on or against this appliance.

DO NOT use store chemicals or flammable materials, or spray aerosols near this appliance.

DO NOT operate with panels or covers removed from the appliance.

FILLING THE WATER HEATER

Open all hot water taps. Open stop cock at the cold water inlet and allow water heater to fill until water flows through the system. Close each hot water tap after the air is expelled from its line.

LIGHTING THE WATER HEATER

The water heater must be filled with water before lighting. Instructions for lighting procedure are on the inside of the access cover and shown in Figure 3.

The access cover is removed by easing the cover up and away from the water heater.

The unit is fitted with a thermostat that incorporates a Thermal Overload Safety Cut-Out. In the event of thermostat failure, the Safety Cut-Out will automatically and permanently cut off the supply of gas to the burner. If this happens, your heater will not light and you should call your local Dux agent.

It is important to fit the drain cap supplied to the unused drain (located on either side of the lower edge of the water heater.) A tube (e.g. standard garden hose) should be connected to the drain on the lower side of the unit which is most suitable, so that water is directed away from any concrete paths.

TESTING THE WATER HEATER

Test operation by lighting the water heater (see *Operating Instructions*). Check that the test point pressure of water heater complies with the Data Plate. Check that the pilot flame plays on the last 4mm of the thermocouple. If necessary, adjust accordingly by following the instructions under "*Commissioning Adjustments*" in the *Service Information*.

LIGHTING INSTRUCTIONS FOR "EUROSIT GAS CONTROL"

Warning: Do not light heater until it is full of water

1. Turn the knob fully clockwise to the "●" (off) position.
2. Wait five (5) minutes so any build-up of unburnt gas can escape.
3. Turn the knob to the "✱" (pilot) position.
4. Depress the knob fully (until "✱" disappears below housing) and after thirty (30) seconds, whilst keeping the knob depressed, repeatedly press the igniter button (for up to 40 seconds) until the pilot flame ignites.

Note: It is not possible to depress the knob fully if the gas control has activated its safety shut-off feature. In this case, wait 60 seconds for the gas control to reset.

5. Keep the knob depressed for twenty (20) seconds after the pilot flame lights. The pilot flame can be observed in the mirror placed directly below the pilot assembly.
6. Release the knob and check if the pilot is still alight.
7. If pilot has failed to light or has not remained alight, turn gas control knob to "●" (off). Wait five (5) minutes for the escape of unburnt gas, then begin again at step 3.
8. When the pilot flame remains alight with the knob released, turn the knob anticlockwise to one of the number settings. A setting of "6" is recommended and this will give a water temperature of about 60°C.
9. Turn the knob to a higher number for higher water temperatures or a lower number for lower water temperatures.
10. Replace the access panel.
11. If the burner does not light at the selected setting, the water may already be at the selected temperature.

Warning: Do not attempt to light if the pilot is out and the knob is in the "ON" position (one of the number settings). Follow steps above.

Thermostat and gas control knob

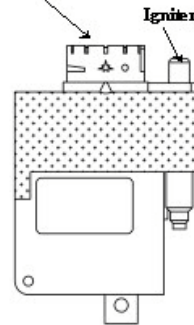

CLOSE-DOWN PROCEDURE

1. Turn the knob to "●" (off) position.
2. Turn water off at water isolating valve.

TO TURN OFF GAS TO THE APPLIANCE

1. Turn the knob to "●" (off) position.
2. Turn off the gas isolation valve.

To maintain safety and efficiency this heater should be serviced annually by an authorised service agent.

TO BE INSTALLED ON A FIREPROOF BASE

Figure 3: Lighting Instructions

RECOGNITION OF ABNORMAL OPERATION

1. PRESSURE AND TEMPERATURE RELIEF VALVE RUNNING

It is not unusual for the valve to allow a small quantity of water to escape during the heating cycle. The amount of discharge will depend on hot water usage. As a guide, if it discharges more than 20 litres of water in 24 hours there may be a problem.

Continuous trickle:

Likely build up of foreign matter. Try gently raising the easing lever on the relief valve for a few seconds. This may dislodge a small particle of foreign matter and rectify the fault. Release lever gently.

Steady flow emitted:

Likely causes are excessive water supply pressure or a faulty pressure valve.

2. NO HOT WATER

Is the relief valve discharging too much water? See *“Pressure and Temperature Relief Valve Running”*.

Do you have the correct size water heater for your requirements? Sizing details are available from your Dux supplier.

Is one outlet (especially the shower) using more hot water than you think? Carefully review the family's hot water usage and if necessary check the shower flow rates with a bucket and a watch. If it is not possible to adjust water usage patterns, an inexpensive flow control valve can easily be fitted to the shower outlet.

3. HIGH GAS BILLS

Is the relief valve discharging too much water? See *“Pressure and Temperature Relief Valve Running”*.

Is one outlet (especially the shower) using more hot water than you think? See *“No Hot Water”*.

Is there a leaking hot water pipe or dripping hot water tap? A small leak can waste a large quantity of hot water.

Replace faulty tap washers and have your plumber rectify any leaking pipework.

SERVICE INFORMATION

SIX MONTHLY SERVICE (BY OWNER)

Operate the Pressure and Temperature Relief Valve for approximately 10 seconds by raising the easing lever on the top of the valve to ensure water is able to be relieved through the relief drain pipe. Check to ensure the valve closes correctly.

ANNUAL SERVICE (BY AUTHORISED PERSONNEL ONLY)

Clean and service the gas burner and pilot.

FIVE YEAR SERVICE (BY AUTHORISED PERSONNEL ONLY)

The five yearly service should be carried out by a licensed Tradesperson. It is recommended that this service be carried out by your local Dux agent. The service should include the following:

- Replace the Pressure and Temperature Relief Valve.
- Replace the anode. In areas of harsh or adverse water conditions, it is recommended that you carry out a more frequent check of your anode's condition. Refer to "Water Quality".
- Clean and service the gas burner and pilot.
- Flush the cylinder.

REMOVAL AND REPLACEMENT OF BAFFLE (BY AUTHORISED PERSONNEL ONLY)

There may be some instances where the baffle may need to be accessed for cleaning, repairs or replacement. To access the baffle, the following steps need to be followed:

- Make sure the gas controller is turned to pilot or off position before commencing.
- Remove the plastic lid from the top of the heater. There are screws at either side of the lid towards the rear and a clipping arrangement at the front which can be popped using a screwdriver, taking care to not scratch the heater case.
- Remove the rockwool insulation blanket. The top of the down duct will now be present, wrapped in foil-backed glass insulation.

Caution: Metal surfaces in this region, including the baffle, may be hot. Use appropriate protection when performing the following procedures.

- Cut the foil-backed insulation as outlined in Figure 4 and peel back the flaps to enable access to the top cover and the screws that secure it.
- Remove the screws (standard tip, short blade length screwdriver required) and tilt the top cover towards the rear of the heater until there is enough clearance to remove the baffle.
- Remove the baffle and replace with either a new baffle of same type (ie for a 330TN, 360TN, 330TL or 360TL) or the same baffle that has been cleaned or repaired.
- Ensure the baffle is hanging correctly and replace the top cover and screws.
- Replace the folds of insulation and seal the cuts with aluminium tape (do not use any other type of tape due to the heat that occurs in this region).
- Replace rockwool and plastic lid and turn gas controller to appropriate setting (ignite, if required, using the instructions outlined in Figure 3). If the baffle is new and has a surface coating of oil, there may be a pungent odour as the oil burns off. Do not be alarmed, as this will only last for a few minutes.

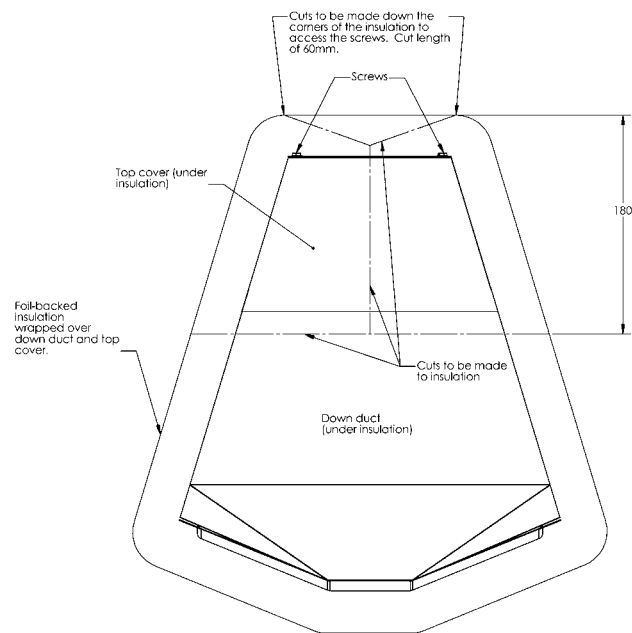

Figure 4: Accessing the Baffle

COMMISSIONING ADJUSTMENTS

(a) Burner Aeration

The aeration is self adjusting. There is no facility or requirement for you to adjust aeration.

(b) Main Gas Pressure Regulator Adjustment

The main burner pressure must be set at installation and should not need readjustment. If adjustment is necessary, proceed as follows: (The pressure is best checked by connecting a water manometer or equivalent to the test point nipple on the gas control. The test point pressure must comply with the value on the Data Plate).

EUROSIT Gas Control:

- (i) Loosen the plastic cover from the top of the gas control and ensure pressure adjustment screw on left hand side is accessible.
- (ii) Remove test point screw from upper nipple on the right hand side of the gas control and attach manometer.
- (iii) Light the burner. Rotate adjustment screw clockwise to increase pressure, or anti-clockwise to decrease pressure.
- (iv) Once pressure is set, rotate thermostat adjustment knob on gas control to pilot setting (see "*Operating Instructions*"). Remove manometer and replace the test point screw.
- (v) Replace the plastic cover.
- (vi) Ensure pilot is still lit (if not, relight as per the "*Operating Instructions*"). Rotate thermostat adjustment knob to desired setting.

Note: *Pressure adjustments at gas cylinder regulator should be conducted as required to ensure correct supply pressure to water heater as per AS5601/AG601.*

(c) Ignition System (Spark Gap)

Check that the gap between the spark electrode and the pilot burner is 3 - 5mm and adjust as necessary. Push the igniter button to test for a spark. (WARNING: Only test the spark gap where there is no build up of gas).

Dux Hot Water Unit

Manufactured by Dux Manufacturing Limited ("Dux")
Terms of Warranty and Replacement Guarantee

THE DUX HOT WATER UNIT THAT YOU HAVE PURCHASED COMES WITH A COMPREHENSIVE 1 YEAR PARTS AND LABOUR WARRANTY AND A GUARANTEE TO REPLACE YOUR HOT WATER UNIT OR FLUE IF THE INNER CYLINDER AND FLUE FAILS WITHIN 10 YEARS. (INCLUDING LABOUR FOR FIRST 5 YEARS) The terms of the Warranty and replacement guarantee are set out below.

WARRANTY

1. Your hot water unit and its components are covered by a 1 year warranty against defective factory parts or workmanship from the date your hot water unit is installed. If the date of installation is unknown, the warranty commences 1 month after the date of manufacture (which can be found on the serial plate on the hot water unit).
2. This warranty is for normal use of the hot water unit and covers the repair and/or replacement of any failed component in the hot water unit or where necessary, the hot water unit itself. Under this warranty Dux will repair or replace the component or hot water unit free of charge (except for certain transport or travelling time costs which may be payable by the owner under clause 8 below). The decision to repair or replace the component or hot water unit will be entirely at the discretion of Dux.
3. The warranty only applies to defects in the hot water unit which have arisen solely due to faulty materials or workmanship.
4. If the inner cylinder or Flue fails on a Dux "Prodigy" hot water unit model No's 330, 360 within a further 4 years after the end of the 1 year warranty period, Dux will provide a free replacement hot water unit or flue including labour at the nearest approved Dux agent or Dux office to the owners home. Under this replacement guarantee, the transport, installation and labour costs of delivering the replacement hot water unit and removing and replacing the existing hot water unit with the replacement hot water unit will be charged to the responsibility of the owner of the existing hot water unit.
5. If the inner cylinder or flue fails on a Dux "Prodigy" hot water unit model No's 330, 360 within a further 5 years after the end of the first 5 year warranty period, Dux will provide a free replacement hot water unit or flue at the nearest approved Dux agent or Dux office to the owners home. Under this replacement guarantee, the transport, installation and labour costs of delivering the replacement hot water unit and removing and replacing the existing hot water unit with the replacement hot water unit will be charged to the responsibility of the owner of the existing hot water unit.

Scope of Warranty and Guarantee

6. The warranty and replacement guarantee do not apply to any defects or damage not due to faulty factory parts or workmanship, including but not limited to defects or damage caused by or resulting from:-
 - a) accidental damage, abuse, misuse, maltreatment, abnormal stress or strain, harsh or adverse water conditions, contamination or corrosion from particles in the water supply, excessive water pressure or temperature or neglect of any kind to the hot water unit or its components.
 - b) alteration or repair of the hot water unit other than by an approved Dux agent or a Technician of a gas or electricity utility approved by Dux.
 - c) attachment of any parts or accessories other than those manufactured or approved by Dux; and
 - d) faulty or improper installation of the hot water unit, including installation otherwise than in accordance with the instructions contained in the owner's manual supplied by Dux.
7. The warranty only applies to the hot water unit and/or components in the hot water unit and does not cover any plumbing or associated parts, including but not limited to, pressure limiting valves, stop cocks, non return valves, electrical switches, pumps or fuses, supplied by any person installing the hot water unit.
8. Where a hot water unit or a component in a hot water unit is replaced by Dux, the balance of any original warranty or replacement guarantee period will remain effective. The replacement part or hot water unit does not carry any additional warranty or replacement guarantee.

9. Where the hot water is located outside the metropolitan area of a capital city and is:-

- a) more than 25 kilometres from a Dux office; or
- b) more than 25 kilometres from a Dux agent

the owner will be responsible under the warranty, for paying the costs of transporting the hot water unit or any component in the hot water unit to and from an approved Dux agent or to a Dux office (including the costs of any insurance associated with that transport) or paying the travelling time of an approved Dux agent to and from the owner's house premises.

10. Where the warranty applies but the hot water unit is installed or located in a position that does not comply with the Dux installation instructions or any relevant statutory requirements, the owner of the hot water unit will be responsible for the costs of:-

- a) the dismantling or removal of cupboards, doors, walls of special equipment and
- b) any labour required.

to gain access to and to bring the unit to a position that complies with the installation instructions or relevant statutory requirements.

11. Dux's obligations under this warranty and replacement guarantee are limited to repairing or replacing the hot water unit or components. To the extent permitted by law, Dux will not be liable for any loss or damage to furniture, carpets, walls, foundations or any other consequential loss of any kind caused by a defect in the hot water unit or any component.

12. Any claim under the warranty or replacement guarantee must include full details of the defect and/or damage to the hot water unit and/or component in the hot water unit. All claims must be made within one month of the detection of the defect.

13. In addition to this warranty and replacement guarantee, certain legislation (including the Trade Practices Act 1974 and consumer protection legislation of the States and Territories) gives the owner certain rights which cannot be excluded, restricted or modified. Nothing in this warranty and replacement guarantee has the effect of excluding, restricting or modifying those rights.

14. In the case of a hot water unit acquired for other than personal domestic or household use, Dux's liability for a breach of a condition or warranty implied by Division 2 of Part V (other than Section 69) of the Trade Practices Act (1974) and any equivalent State or Territory legislation is expressly limited to any one or more of the following, as determined by Dux:-

- a) the replacement of the hot water unit;
- b) the repair of the hot water unit;
- c) the payment of the cost of replacing the hot water unit or of acquiring an equivalent hot water unit;
- d) payment of the cost of having the hot water unit repaired.

SPECIFICATIONS

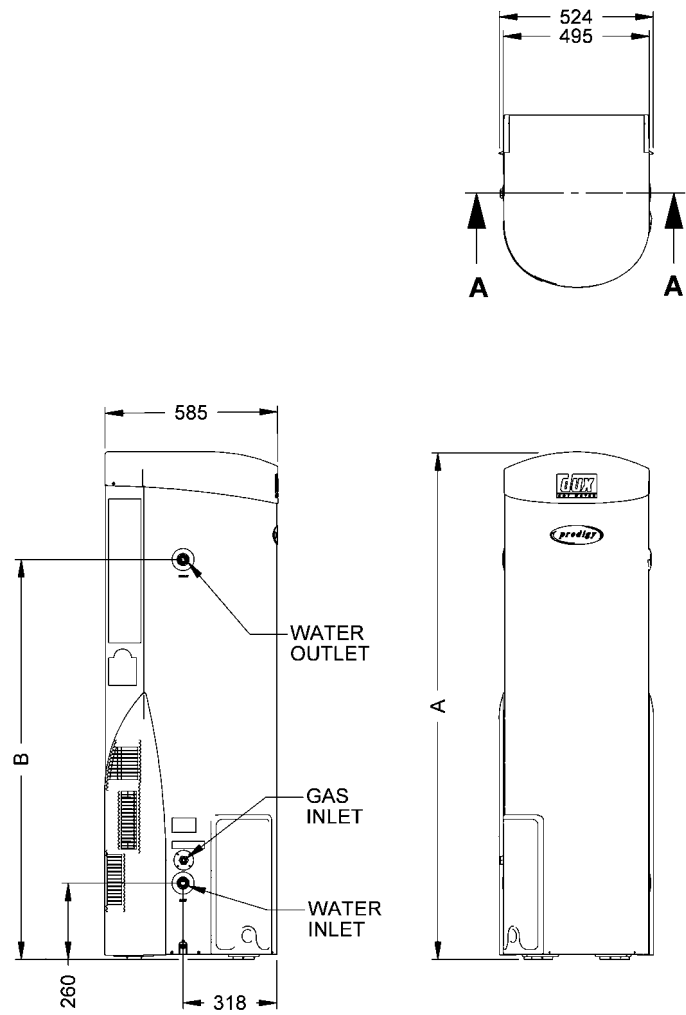

Figure 5: Dimensions of Unit

MODEL:	DIMENSIONS (mm)	
	A	B
330	1727	1360
360	2050	1684