



Owner's Manual

prodigy 4 & 5

Gas Hot Water Heaters

4 Star Models: 135ZB4N / 135ZB4P
170ZB4N / 170ZB4P

5 Star Models: 135DC5N / 135DC5P
170DC5N / 170DC5P



Installation Details

Owner's Information

Warranty

For advice, repairs and service, call:

1300 365 115 (Australia)



Carefully remove all packaging and transit protection from the heater before installation. Dispose of the packaging responsibly using re-cycling facilities where they exist.

Specifications and materials may change without notice.
Effective for all Prodigy 4 & 5 water heaters manufactured and sold after 1st September 2021.



Contents

Installation Requirements	1
Specifications	4
Plumbing Connections	5
Gas Connection and Filling	7
Lighting the Water Heater	8
Shut Down and Draining	9
Testing	10
Owner's Information	11
System Maintenance	13
Considering a Service Call?	14
Warranty	15



Installation Requirements

WARNING – THIS APPLIANCE MAY DELIVER WATER AT HIGH TEMPERATURE. REFER TO THE PLUMBING CODE OF AUSTRALIA (PCA), LOCAL REQUIREMENTS AND INSTALLATION INSTRUCTIONS TO DETERMINE IF ADDITIONAL DELIVERY TEMPERATURE CONTROL IS REQUIRED.

WARNING – FOR CONTINUED SAFETY OF THIS APPLIANCE IT MUST BE INSTALLED, OPERATED AND MAINTAINED IN ACCORDANCE WITH THE MANUFACTURER'S INSTRUCTIONS.

General:

This water heater must be installed by a licensed tradesperson, and in accordance with:

- In Australia, the Plumbing Code of Australia (PCA);
- AS/NZS 5601.1 Gas Installations – General Installations.
- Local authority regulations.
- Outside Australia, please refer to local plumbing and building codes and regulations.

Failure to comply with these requirements may affect your warranty.

AS/NZS 3500.4 Plumbing and Drainage – Heated Water Services provides a Deemed-to-Satisfy Solution for the PCA. Other methods of compliance are available. Dux recommends that installations conform to AS/NZS 3500.4.

Note for Victoria:

This water heater must be installed by a licensed person as required by the Victorian Building Act (1993).

Only a licensed person will provide a compliance certificate, showing that the work complies with all the relevant Standards. Only a licensed person will have insurance protecting their workmanship.

Pool Heating:

This water heater must **not** be used for pool heating.

Location:

The water heater must be installed **outdoors**.

The water heater should be located as close as possible to the most frequently used hot water outlet while still complying with the clearances specified in clause 6.9 of AS/NZS 5601.1.

See Clearances on page 2 for further information.

Ensure that the compliance plate and associated warnings are clearly visible. Adequate access must be available for service to the gas controls, relief valve and anode.

The water heater must not be installed below ground level or in a location where water pools. The water heater must be accessible without the use of a ladder or scaffold.

The water heater must be installed upright with its back against an external wall.



Installation Requirements

Note - all models are equipped with sacrificial anodes, most are accessible through the top cover. It is recommended that a distance of 50% of the height of the water heater is provided as clearance above the water heater. This will assist in the replacement of the anodes.

Clearances:

Clause 6.9 of AS/NZS 5601.1 specifies the minimum clearances required between the water heater and building features, structures and other items.

As a guide, some of the common clearance requirements are set out below:

- At least 300 mm below any eaves, balconies or other projections.
Note that at least half the height of

the water heater is recommended as clearance to provide access to the anode.

- At least 500 mm from any external corner.
- At least 500 mm from any return wall or other structure facing the side of the water heater.
- At least 1000 mm from any gas meter.
- At least 500 mm from any electricity meter or fuse box.
- At least 500 mm from any openable window or door.

For a full list of the requirements and exemptions please refer to AS/NZS 5601.1.

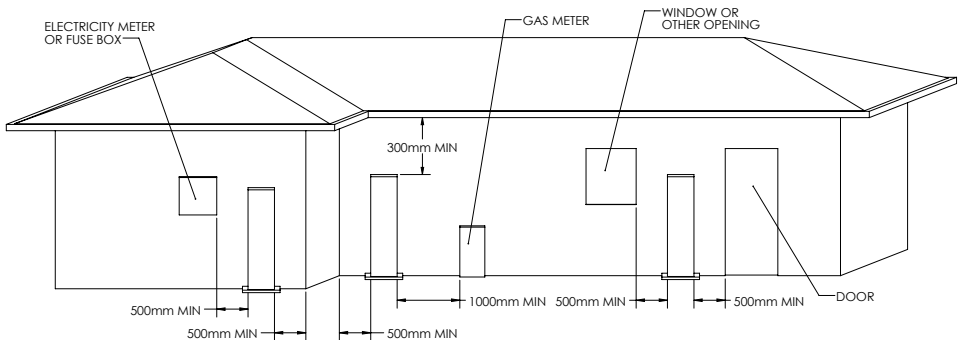



Installation Requirements

Water Heater Support:

The water heater must be installed on a flat, solid, non-combustible supporting surface. The weight of the water heater should not cause deformation to any part of the building structure.

It is recommended that a plinth is installed under the water heater.

The water heater must be installed plumb and level.

The water heater must also be secured to a durable structure using the wall brackets supplied loose with the water heater. Note that the gas or water pipework must not be used to support the water heater.

The wall brackets are designed to be installed on each side of the water heater with the long leg against the side of the water heater and the short leg against the wall. The brackets should be located near the top of the water heater, approximately in line with the Outlet and Relief Valve sockets. Note that once installed, the brackets should not obscure any labels on the water heater.

The brackets should be fixed to the wall with suitable fasteners and fixed to the water heater with the self drilling screws provided.

Water Supply:

This water heater has been manufactured to suit the water conditions of most Australian metropolitan supplies.

Please note that certain water supplies can have a detrimental effect on the water heater and its life expectancy. If you are unsure about the water supply you can obtain information from the local water supply authority.

The water heater is designed for use in areas where the Total Dissolved Solids (TDS) content of the water supply is less than 2500 mg/L. The Tank Failure Warranty does not apply in areas where the TDS exceeds 2500 mg/L.

In areas where the TDS exceeds 600mg/L it is possible that the magnesium alloy anode (supplied in standard water heaters) may become overreactive. To alleviate this, the magnesium anode should be replaced with an aluminium alloy anode. Aluminium alloy anodes are available from your local Dux Supplier.

Water can also be very corrosive, the measure of this is the saturation index. If the water saturation index is greater than 0.40, an expansion control valve should be fitted. Please consult Dux After Sales and Service for advice if required.



Specifications

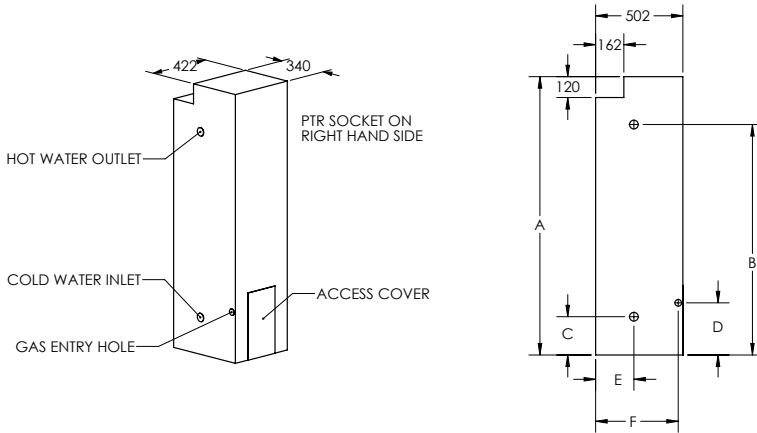

Specifications	135L		170L	
	Capacity (L)	135	135	170
Gas Type	Natural Gas	Propane	Natural Gas	Propane
4 Star Net Weight Empty (kg)	72	72	86	86
5 Star Net Weight Empty (kg)	73	73	87	87
Relief Valve Pressure (kPa)	1400	1400	1400	1400
Injector Size (mm)	2.35	1.40	2.55	1.55
Gas Supply Pressure Min	1.13 kPa	2.75 kPa	1.13 kPa	2.75 kPa
Gas Supply Pressure Max	3.50 kPa	3.50 kPa	3.50 kPa	3.50 kPa

Gas Consumption (MJ/h) data is marked on the product data label which is fixed to the water heater.

Nominal Dimensions	135L	170L
A – Overall Height (mm)	1600	1895
B – Outlet Height (mm)	1325	1620
C – Inlet Height (mm)	220	220
D – Gas Entry Height (mm)	300	300
E – Inlet/Outlet Offset (mm)	220	220
F – Gas Entry Offset (mm)	475	475



Plumbing Connections

Relief Valve:

The Pressure & Temperature Relief (PTR) Valve is supplied loose with the water heater.

The PTR Valve rating is 1400 kPa.

The PTR Valve rating is also shown on the compliance plate. The PTR Valve must be installed directly into the RP $\frac{1}{2}$ "(DN15) socket marked "RELIEF VALVE" at the top of the water heater on the right hand side.

Ensure that a sealing material is applied to the PTR Valve to prevent water leaks.

The drain line from this valve must be made of copper and run in accordance with the requirements of AS/NZS 3500.4.

The PTR Valve and its drain outlet pipe must not be sealed or blocked.

A separate drain line must be run for the valve. It is not permitted to couple drain lines from relief valves into a single common drain line.

It is normal for the valve to leak a small amount of water during heating cycles.

The PTR Valve is not intended to enable connection of the water heater to supplementary energy sources such as solar panels or slow combustion stoves.

Refer to AS/NZS 3500.4 for guidance on these types of installations.

Fit the insulation supplied with the water heater to the PTR Valve, after the PTR is installed. Ensure the PTR lever is not obstructed by the fitment of the insulation. See below.

Caution:

Care must be taken when attaching pipe saddles to the water heater. We recommend the use of self drilling screws no longer than 12 mm.

Hot Water Connection:

The hot water pipe is to be connected into the RP $\frac{3}{4}$ "(DN20) socket marked "OUTLET" at the top of the water heater on the left hand side.

It is recommended that all hot water pipes are insulated. Hot water pipes installed outdoors should be insulated with UV stabilised insulation.

Plastic pipes or fittings shall not be used within 1 metre of the outlet although they may be used downstream of a temperature control valve. Refer to AS/NZS 3500.4 for further details.

INSULATION TO BE FITTED AFTER PTR VALVE IS INSTALLED

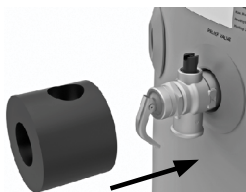

Scan QR code for Installation Video





Plumbing Connections

Temperature Protection:

Water heaters can produce very hot water. To reduce the risk of scald injury, it is mandatory under the requirements of AS/NZS 3500.4 that an approved temperature control device be fitted to the hot water supply to outlets used primarily for personal hygiene. This valve should be checked at regular intervals to ensure its operation and settings remain correct.

Cold Water Connection:

The water heater is intended to be permanently connected to the water supply main.

An approved isolating valve, non-return valve, line strainer (optional but recommended) and union must be fitted between the water supply main and the RP $\frac{3}{4}$ "(DN20) socket marked "INLET" at the bottom of the water heater on the left hand side.

All fittings must be approved by the relevant Authority. Plastic pipes or fittings shall not be used between the isolating valve and the inlet.

See the diagram below for details.

Water Supply Pressure:

This water heater is designed for direct connection to water supply pressures of up to **1120 kPa**.

Where the mains pressure can exceed or fluctuate beyond the pressure shown above, a pressure reducing valve must be fitted in the cold water inlet supply.

Note for South Australia and Western Australia:

It is a requirement in these locations that an expansion control valve be fitted on the cold water supply line between the non-return valve and the water heater.

Cold Water Connections

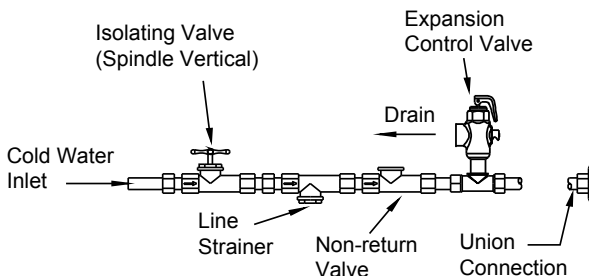

Note: a combined isolating valve/non-return valve/line strainer may be used.

The expansion control valve is only required where local regulations demand, although it is recommended in areas where the water saturation index is greater than 0.40.



Gas Connection and Filling

Gas Connection:

Ensure that the gas type to be connected matches the gas type marked on the compliance plate of the water heater.

The gas pipe should be sized in accordance with AS/NZS 5601.1. An isolation valve must be installed in the gas pipe before it enters the water heater.

The gas pipe must be connected via the gas entry hole on the left hand side of the water heater. See Specifications on page 4 for the location of the entry hole.

Ensure that the black plastic grommet, supplied loose with the water heater, is slid over the gas pipe before the connections are completed. The grommet must then be clipped into the case.

A union should be used to connect the gas pipe to the RP $\frac{1}{2}$ " (DN15) socket on the gas control valve. Ensure that the union is not over-tightened in the gas control valve.

The water heater must be filled with water before lighting the gas.

Filling the Water Heater:

1. Open all hot water taps.
2. Open the isolating valve at the cold water inlet slowly and allow the water heater to fill until water flows through the system.
3. Close each hot water tap after the air is expelled from its line.
4. Open the Pressure & Temperature Relief Valve for approximately 10 seconds by lifting the easing lever on the valve. Confirm that water drains to waste through the relief valve drain pipe.
5. Lower the lever gently and check that it closes correctly.



Lighting the Water Heater

Caution:

Do not light the water heater until it has been filled with water (see Filling the Water Heater on page 7).

Do not attempt to light the water heater if the pilot is out and the knob is in the "ON" position (one of the number settings). Follow the steps below.

Important Safety Note:

Do not look directly into the burner area. Keep your head above the top of the access cover opening. Use a mirror to observe the flame.



Lighting Procedure:

The diagram on the next page shows the location of the control knob and the igniter button on the gas control valve.

1. Remove the access cover. (A copy of the lighting procedure can also be found on the inside of the access cover).
2. Turn the control knob fully clockwise to the "●" (off) position.
3. Wait five (5) minutes so any build-up of unburnt gas can escape.
4. Turn the control knob to the ★ (pilot) position.
5. Depress the control knob fully (until ★ disappears below housing) and after thirty (30) seconds, whilst keeping the control knob depressed, repeatedly press the igniter button (for up to 40 seconds) until the pilot flame ignites. Note - it is not possible to depress the control knob fully if the gas control valve has activated its safety shutoff feature. In this case, wait sixty (60) seconds for the gas control valve to reset.
6. Keep the control knob depressed for twenty (20) seconds after the pilot flame lights. Use a mirror to observe the pilot flame. Do not attempt to observe the flame directly.
7. Release the control knob and check the pilot is still alight.
8. If the pilot has failed to light or has not remained alight, turn the control knob to "●" (off). Wait five (5) minutes for the escape of unburnt gas, then begin again at step 4.
9. When the pilot flame remains alight with the control knob released, turn the control knob anticlockwise to one of the number settings. A minimum setting of "6" is recommended and this will give a water temperature of about 60°C.
10. Turn the control knob to a higher number for higher water temperatures.
11. If the main burner does not light at the selected setting, the water may already be at the selected temperature.
12. Replace the access cover and ensure it is firmly in position.



Shut Down and Draining

Shutting Down the Water Heater:

1. Remove the access cover and turn the control knob to the “•” (off) position.
2. Turn off the gas isolation valve.
Never turn off the gas supply without turning the control knob to the off position first.
3. Turn off the cold water supply isolation valve.
4. Replace the access cover.

Draining the Water Heater:

1. Shut down the water heater by carrying out the steps listed at left.
2. Gently operate the easing lever on the Pressure & Temperature Relief (PTR) Valve to release the pressure in the water heater.
3. Disconnect the cold water inlet union to the water heater and attach a drain hose.
4. Gently operate the easing lever on the PTR Valve to let air into the water heater and allow water to escape through the hose.

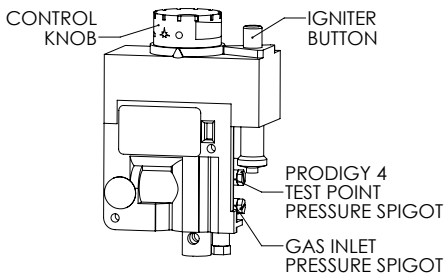

GAS CONTROL VALVE DIAGRAM

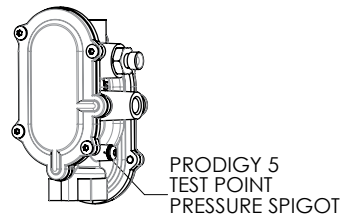

RELAY VALVE DIAGRAM

The Relay Valve diagram is for the Prodigy 5 star models only.



Testing

The operation of the water heater must be tested by the installer. This work must only be done by a licensed tradesperson.

Test for Leaks:

Check the water inlet, water outlet and gas inlet pipe work and connections for leaks.

Test the Gas Inlet Pressure:

For correct operation of the water heater, the gas inlet pressure must be at least:

Natural Gas	1.13 kPa
Propane	2.75 kPa

To test the gas inlet pressure, follow the procedure below. If the pressure is less than the above value, there could be a problem with the gas meter or supply pipe size.

1. Ensure the water heater has been filled with water and the gas isolation valve is turned off.
2. Remove the lower of the two hex head screws on the right hand side of the gas control valve and fit a manometer to the spigot.
3. Turn on the gas isolation valve and light the water heater. See Lighting the Water Heater on page 8.
4. If necessary, adjust the control knob until the main burner lights.
5. With the main burner alight, measure the pressure.
6. Turn the thermostat knob to the “●” (off) position and turn off the gas isolation valve.
7. Disconnect the manometer and replace the screw removed at step 2.

Test the Gas Test Point Pressure:

For correct operation of the water heater, the gas test point pressure must be within 5% of the value marked on the compliance plate.

4 Star: To test the gas test point pressure, follow the same procedure used for the gas inlet pressure except that the upper of the two hex head screws is to be removed at step 2.

5 Star: To test the gas test point pressure, follow the same procedure used for the gas inlet pressure except that the M4 button head screw on the right hand side of the relay valve is to be removed at step 2. A 2.5mm allen key is supplied with the water heater for this purpose.

If the pressure is not within 5% of the marked value, contact Dux After Sales and Service for advice.

Final Checks:

- Turn on the gas isolation valve and light the water heater.
- Make sure there are no gas leaks from either of the two screws removed during gas pressure testing.
- Set the gas control knob to position “6” unless hot water is not required.
- Replace the access cover.
- Hand this manual to the occupier of the premises and explain the lighting procedure if required.



Owner's Information

Safety:

This water heater is not intended for use by persons (including children) with reduced physical, sensory or mental capabilities, or lack of experience and knowledge, unless they have been given supervision or instruction concerning use of the water heater by a person responsible for their safety.

Children and animals should be supervised to ensure that they do not interfere with the water heater.

DO NOT SPRAY AEROSOLS IN THE VICINITY OF THIS WATER HEATER WHILE IT IS OPERATING.

DO NOT USE OR STORE FLAMMABLE MATERIALS OR CHEMICALS IN OR NEAR THIS WATER HEATER.

DO NOT STORE ANY FLAMMABLE OR COMBUSTIBLE MATERIALS ON OR WITHIN 1 METRE OF THE WATER HEATER.

DO NOT PLACE ARTICLES ON OR AGAINST THE WATER HEATER.

DO NOT PLACE ARTICLES ON OR AGAINST THIS WATER HEATER.

DO NOT MODIFY THIS WATER HEATER.

DO NOT OPERATE THE WATER HEATER WITH ANY PANELS OR COVERS REMOVED.

Relief Valve:

The Pressure & Temperature Relief (PTR) Valve must be installed directly into the top socket marked "RELIEF VALVE".

The PTR Valve rating is shown on the compliance plate. The valve must not be tampered with or removed. The water heater must not be operated unless this valve is fitted and in working order.

The PTR Valve should be checked by a licensed tradesperson for adequate performance, or replaced at intervals not exceeding 5 years, or less in areas where local regulations apply.

The PTR Valve is to be operated regularly to remove lime deposits and to verify that it is not blocked. It is normal for the valve to leak a small amount of water during heating cycles.

Danger:

Failure to operate the PTR Valve easing lever at least once every six months may result in the water heater failing.

Continuous leakage of water from the PTR Valve may indicate a problem with the water heater. This may be caused by excessive water supply pressure, a faulty PTR Valve or a faulty Gas Control Valve.

Shut down the water heater and contact Dux After Sales and Service.



Owner's Information

Gas Control Valve:

As well as acting as a thermostat, the gas control valve is fitted with over temperature energy cut-outs.

The gas control valve must not be tampered with or bypassed.

Replacement of the gas control valve must only be carried out by a licensed tradesperson or the manufacturer.

The water heater must not be operated unless the gas control valve is fitted and in working order.

Temperature Protection:

Water heaters can produce very hot water. To reduce the risk of scald injury, it is mandatory that an approved temperature control device be fitted to the hot water supply to outlets used primarily for personal hygiene. This device should be checked at regular intervals to ensure its operation and settings remain correct.

Not Using Hot Water?

If you are not expecting to need hot water for more than a few days, the control knob on the gas control valve thermostat can be set to the  (pilot) position to conserve energy. Alternatively, the water heater can be shut down.

If the water heater is not used for two weeks or more, a quantity of hydrogen (which is highly flammable) may accumulate inside the water heater tank.

To dissipate this gas safely it is recommended that a hot tap be turned on for several minutes at a sink, basin or bath, but not a dishwasher, clothes washer or other appliance.

During this procedure there must be no smoking, open flame or any other electrical appliance operating nearby. If hydrogen is discharged through the tap it will probably make a sound similar to that of air escaping.

Water Heater Appears to be Leaking:

If the water heater is heating a large quantity of cold water, condensation may form inside the water heater and drip down onto the burner.

This is NOT an indication that the water heater is leaking, but is the result of an efficient gas combustion process.



Owner's Manual – Prodigy 4 & 5

System Maintenance

Regular servicing will help to extend the life of the water heater, and keep it operating safely and efficiently.

Your water heater warranty is not conditional on completing the regular servicing recommended in this manual.

The conditions applying to your water heater warranty are set out on page 15 of this manual.

Six Month Service:

This service may be carried out by the owner.

1. Stand clear of the Pressure & Temperature Relief (PTR) Valve drain pipe outlet.
2. Open the PTR Valve for approximately 10 seconds by lifting the easing lever on the valve. Confirm water discharges to waste through the drain pipe.
3. Lower the easing lever gently and check it closes correctly.
4. Repeat the above process for the expansion control valve (if installed).

Other than this, personally inspecting or servicing any part of the water heater is not recommended.

Annual Service:

This service should only be carried out by a licensed tradesperson. We recommend your local Dux Service Agent.

The service should include the following:

- Inspect and flush the PTR Valve and expansion control valve (if installed).
- Check the spark gap, gas control valve and thermocouple.
- Check and if necessary adjust the main burner pressure.
- Clean and check the main burner and the pilot light.

Five Year Service:

This service should only be carried out by a licensed tradesperson. We recommend your local Dux Service Agent.

In locations where the water has Total Dissolved Solids (TDS) exceeding 600 mg/L, this service is recommended every 3 years.

In addition to the items listed in the Annual Service, this service should include the following:

- Replace the PTR Valve.
- Replace the anodes.
- Drain and flush the water heater.
- Replace any damaged components.

Replacement parts are available from your local Dux supplier.



Considering a Service Call?

It is recommended that the following points be reviewed before making a service call:

No Hot Water:

Confirm the pilot is alight. If it is not, see Lighting the Water Heater on page 8.

High Gas Bills or Insufficient Hot Water:

- Consider that often the hot water usage of showers, washing machines and dishwashers can be under estimated. Review these appliances to determine if the daily usage is greater than the capability of the water heater.
- If necessary check the shower flow rates with a bucket, measuring the amount of water used over a period of time. If it is not possible to adjust water usage patterns, an inexpensive flow control valve can easily be fitted to the shower outlet.
- Is the water heater the correct size for the requirements? Sizing details are available from your Dux supplier.
- Is there a leaking hot water pipe or dripping hot water tap? A small leak can waste a large quantity of hot water. Replace faulty tap washers and arrange for your plumber to rectify any leaking pipe work.

- Is the Pressure & Temperature Relief Valve discharging too much water? See below.

Continuous Trickle of Water from Pressure & Temperature Relief (PTR) Valve:

This is most likely due to a build up of foreign matter. In this case, try gently raising the easing lever on the PTR Valve for a few seconds, then release gently.

This may dislodge a small particle of foreign matter and rectify the fault.

Water Discharge from PTR Valve:

It is not unusual for a small quantity of water to discharge during the heating of water in the storage tank. The amount of discharge will depend on hot water usage and the size of the storage tank.

As a guide, it will discharge about 2% of the volume of the water heated.

Continuous leakage of water from the PTR Valve may indicate a problem with the water heater. Shut down the water heater and contact Dux After Sales and Service.

If after checking the above points, the problem has not been identified, please contact Dux After Sales and Service.



Warranty

Dux Gas Storage Water Heater - Warranty Summary:

Your water heater is specified with a warranty as set out in the table below.

The fault must appear within the defined time period, which commences from the date of installation (or manufacturing date of the unit if proof of the date of installation is not available) in order to be covered.

Dux Prodigy 4 Water Heater Warranty

Dux Prodigy 4 Water Heater Warranty	Tank Warranty	Parts & Labour
Single Family Dwelling	7 years	1 year
All Other Applications	3 years	1 year

Dux Prodigy 5 Water Heater Warranty

Dux Prodigy 5 Water Heater Warranty	Tank Warranty	Parts & Labour	
Single Family Dwelling	10 years	Flue Damper	5 years
		All other parts	1 year
All Other Applications	3 years	Flue Damper	1 year
		All other parts	1 year

The benefits provided to you by this warranty are in addition to any other rights and remedies available to you under the Australian Consumer Law.

Parts and Labour Warranty:

Dux Manufacturing Limited (“Dux”) warrants against defects in the water heater arising from faulty materials or workmanship.

During the period (as specified in the table above), Dux will repair or replace any failed component or where necessary, at the absolute discretion of Dux, replace the water heater, free of charge including reasonable labour costs incurred during normal business working hours.

Tank Failure Warranty:

Dux warrants against failure of the storage tank, in accordance with its application (as specified in the table above). Conditions apply.

During the first year of warranty, Dux will provide a replacement water heater free of charge including installation and labour costs.

Installation and other labour costs are the responsibility of the owner if the water heater is outside parts and labour warranty.



Warranty

Warranty Conditions:

The warranty only applies to the water heater itself and the components supplied with the water heater by Dux. The warranty does not cover components supplied by others, including the installer.

The tank failure warranty does not apply if the water heater has been connected to a water supply where the Total Dissolved Solids content is greater than 2500 mg/L.

These warranties do not apply to defects that are a result of, without limitation, the following:

- failure to install the water heater in accordance with the installation instructions or statutory requirements;
- faulty plumbing or gas supplies including excessive pressure;
- use of the water heater in a manner contrary to this manual or other instructions provided by Dux;
- alterations or repair of the water heater other than by an accredited and licensed service agent or technician;
- accidental damage or abuse.

If the water heater is installed in a position that does not comply with the installation instructions or statutory requirements, then this warranty does not cover major dismantling or removal of cupboards, doors, walls or special equipment and/or excessive labour, at the determination of Dux, to make the water heater accessible for repair or replacement.

Where the Dux water heater is located outside the metropolitan area of a capital city and is more than 100km from a Dux office or Dux agent, the Owner will be responsible under the warranty for paying the costs of transporting the water heater and or any component in the water heater to and from an approved Dux agent or Dux office (including any insurance associated with that transport), or paying the travelling time of an approved Dux agent to and from the owners premises.

Commencement of Warranty:

The warranty period commences from the date of installation of the water heater. Where proof of the date of installation is not available, the warranty period commences on the date of manufacture of the water heater. This is shown on the compliance plate on the outside of the water heater.

The replacement of the water heater, or a component of it, under this warranty does not change the warranty commencement date. The original commencement date continues to apply.

Exclusion and Limitation of Liability:

In addition to any other provisions set out in this document and to the maximum extent permitted by any applicable law or regulation, Dux will not be liable for any claim:

1. for consequential loss to any property arising directly or indirectly out of or connected to the supply or installation of the water heater. This includes but



Warranty

- is not limited to furnishings, carpets, foundations, housing effects and buildings.
2. for any direct or indirect economic or financial loss of any nature.
 3. arising out of or connected to a water heater that has been resold or moved from its original installation location.
 4. arising out of or connected to any misuse, or other use, installation or maintenance that is not in accordance with the procedures and requirements set out in this document.

To the extent permitted by law the liability of Dux shall be limited to the cost of the repair or replacement of the water heater.

The Australian Consumer Law (“ACL”):

Our goods come with guarantees that cannot be excluded under the Australian Consumer Law. You are entitled to a replacement or refund for a major failure and compensation for any other reasonably foreseeable loss or damage. You are also entitled to have the goods repaired or replaced if the goods fail to be of acceptable quality and the failure does not amount to a major failure.

If Dux fails to meet a guarantee under the ACL, your remedy for such failure may be limited to any one or more of the following:

- replacement of the water heater;
- repair of the water heater;
- refunding the cost of the water heater;
- payment of the reasonable costs of

- having the water heater repaired;
- payment in respect of the reduced value of the water heater.

How to Make a Warranty Claim:

Warranty claims can be placed by completing the following steps:

- Contact Dux on one of the numbers listed below.
- Select the “Service” option followed by the “Hot Water” option.
- Provide the serial number and model number of the water heater. This can be found on the compliance plate on the outside of the water heater.
- Provide your full name, address and contact number.
- Provide proof of date of installation for warranty to commence from that date, rather than from the date of manufacture. See Commencement of Warranty on page 16.

Please note that if the defect or fault is not covered by the warranty or guarantee, you will be responsible for the costs incurred by the service agent or technician.

Dux service calls can only be scheduled during business hours (AEST) Monday to Friday and are not available on weekends & public holidays.

Contact Details:

Dux Manufacturing Limited
Lackey Road, Moss Vale, NSW, 2577
Australia
1300 365 115 (Australia)
Email: duxaftersales@dux.com.au

prodigy 4 & 5

Gas Storage Water Heaters

For advice, repairs and service, call:
1300 365 115 (Australia)

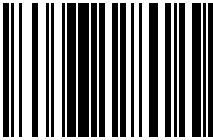

H3109

Please Register Your Water Heater



Please take a moment to fill out your details for warranty registration at:

www.dux.com.au/warranty

or use your smartphone to scan this code:



This will ensure all your current details are registered with us for prompt warranty service if required.

To view our privacy policy please visit <http://www.dux.com.au/p/privacy>

Date of Installation:

Installer's Name:

Installer's Company:

Installer's Licence No:

Installer's Signature:

Serial Number