



# Installation and Owner's Manual

## IMPORTANT INFORMATION

Failure to follow these instructions may affect the Warranty

# ecosmart®

## Heat Pump Water Heater

Model: 200DHA20, 200DHA20P,  
300DHA20, 300DHA20P

Installation Details

Owner's Information

Warranty

For advice, repairs and service, call:

1300 365 115 (Australia)

0800 729 389 (New Zealand)



Carefully remove all packaging and transit protection from the heater before installation. Dispose of the packaging responsibly using re-cycling facilities where they exist.



Specifications and materials may change without notice.  
Effective for Ecosmart® water heaters manufactured and sold after 1st October 2023.

H4128 Rev. D



## Important Safety Information

**WARNING – THIS APPLIANCE MAY DELIVER WATER AT HIGH TEMPERATURE. REFER TO THE PLUMBING CODE OF AUSTRALIA (PCA), LOCAL REQUIREMENTS AND INSTALLATION INSTRUCTIONS TO DETERMINE IF ADDITIONAL DELIVERY TEMPERATURE CONTROL IS REQUIRED.**

**WARNING – FOR CONTINUED SAFETY OF THIS APPLIANCE IT MUST BE INSTALLED, OPERATED AND MAINTAINED IN ACCORDANCE WITH THE MANUFACTURER'S INSTRUCTIONS.**

This water heater is not intended for use by persons (including children) with reduced physical, sensory or mental capabilities, or lack of experience and knowledge, unless they have been given supervision or instruction concerning use of the water heater by a person responsible for their safety.

Children should be supervised to ensure they do not interfere with the water heater. Ensure animals are supervised so they do not interfere with the water heater.

**DO NOT STORE CHEMICALS OR FLAMMABLE MATERIALS, OR SPRAY AEROSOLS NEAR THIS WATER HEATER.**

**DO NOT STORE ANY COMBUSTIBLE MATERIAL NEAR THIS WATER HEATER.**

**DO NOT MODIFY THIS WATER HEATER.**

**DO NOT OPERATE THE WATER HEATER WITH ANY PANELS OR COVERS REMOVED.**

**DO NOT INSERT YOUR FINGER, A STICK, OR OTHER OBJECTS INTO THE**

**AIR INLET & OUTLET GRILLS. THIS MAY CAUSE INJURY, SINCE THE FAN INSIDE ROTATES AT HIGH SPEEDS DURING OPERATION.**

**WARNING – IF THE WATER HEATER IS NOT USED FOR TWO WEEKS OR MORE, A QUANTITY OF HYDROGEN (WHICH IS HIGHLY FLAMMABLE) MAY ACCUMULATE INSIDE THE WATER HEATER TANK. TO DISSIPATE THIS GAS SAFELY IT IS RECOMMENDED THAT A HOT TAP BE TURNED ON FOR SEVERAL MINUTES AT A SINK, BASIN OR BATH, BUT NOT A DISHWASHER, CLOTHES WASHER OR OTHER APPLIANCE. DURING THIS PROCEDURE THERE MUST BE NO SMOKING, OPEN FLAME OR ANY OTHER ELECTRICAL APPLIANCE OPERATING NEARBY. IF HYDROGEN IS DISCHARGED THROUGH THE TAP IT WILL PROBABLY MAKE A SOUND SIMILAR TO AIR ESCAPING.**

### **RELIEF VALVE:**

The Pressure & Temperature Relief (PTR) Valve must be installed directly into the RP $\frac{1}{2}$ " (DN15) socket marked "RELIEF VALVE".

The PTR Valve rating is 1,000 kPa and 10 kW.

The valve must not be tampered with or removed. The water heater must not be operated unless this valve is fitted and in working order.

The drain line from the PTR Valve must be installed in a continuously downward direction in a frost free environment.

The PTR Valve is to be operated regularly to remove lime deposits and to verify it is not blocked. The drain line fitted to the PTR Valve must be left open to the atmosphere.



## Important Safety Information

**DANGER: FAILURE TO OPERATE THE PTR VALVE EASING LEVER AT LEAST ONCE EVERY SIX MONTHS MAY RESULT IN THE WATER HEATER EXPLODING. CONTINUOUS LEAKAGE OF WATER FROM THE VALVE MAY INDICATE A PROBLEM WITH THE WATER HEATER.**

The PTR Valve should be checked by a licensed tradesperson for adequate performance, or replaced at intervals not exceeding 5 years, or less in areas where local regulations apply.

It is normal for water to drip from the drain line fitted to the PTR Valve during heating cycles.

Continuous leakage of water from the PTR Valve may be caused by excessive water supply pressure, a faulty PTR Valve or a faulty thermostat.

Turn off the water heater and contact Dux After Sales and Service.

### **OVER-TEMPERATURE ENERGY CUT-OUT:**

The operation of the over-temperature energy cut-out on the thermostat indicates a possibly dangerous situation. Do NOT reset the overtemperature energy cut-out until the water heater has been serviced by a licensed tradesperson.

### **ELECTRICAL SAFETY:**

This water heater is designed for single phase 230 - 240V a.c. supply only. The electrical connection must comply with Local Supply Authority Regulations and AS/NZS 3000 (known as the Wiring Rules). A means for disconnection must be incorporated in the fixed wiring in accordance with the Wiring Rules.

Any electrical covers should be removed only by a licensed tradesperson, and only after the electrical supply to the water heater has been isolated.

**When the supply wiring has been connected, ensure the wires are kept lower than the terminal block.**

**Warning- Do not replace the heating element with one of higher heating capacity.**

Excess wire is not to be looped close to the thermostat or tank.

In addition to the PTR Valve, the water heater is fitted with a combination thermostat and over-temperature energy cut-out.

These devices must not be tampered with or removed. Replacement of these devices must only be carried out by a licensed tradesperson or the manufacturer.

The water heater must not be operated unless these devices are fitted and in working order.

### **COLD WATER CONNECTION:**

The water heater is intended to be permanently connected to the water supply main, and not connected by a hose-set.

This water heater is designed for direct connection to water supply pressures of up to 800 kPa.

Where the mains pressure can exceed or fluctuate beyond this pressure, a pressure reducing valve must be fitted in the cold water inlet supply.

Instructions explaining how the water heater can be drained can be found on page 6.



# Important Safety Information

## INSTALLATION REQUIREMENTS

### General:

This water heater must be installed by a licensed tradesperson, and in accordance with:

- In Australia, the Plumbing Code of Australia (PCA);
- In New Zealand, Clause G12 of the New Zealand Building Code (NZBC);
- AS/NZS 3000 Electrical Installations (known as the Australian / New Zealand Wiring Rules); and
- Local authority regulations.

Outside Australia and New Zealand, please refer to local plumbing and building codes and regulations.

Failure to comply with these requirements may affect the warranty.

AS/NZS 3500.4 Plumbing and Drainage – Heated Water Services provides a Deemed-to-Satisfy Solution for the PCA and a Verification Method for Clause G12 of the NZBC. Other methods of compliance are available. Dux recommends that installations conform with AS/NZS 3500.4.

### Note for Victoria:

This water heater must be installed by a licensed person as required by the Victorian Building Act (1993).

Only a licensed person will provide a compliance certificate, showing that the work complies with all the relevant Standards. Only a licensed person will have insurance protecting their workmanship.

### Pool Heating:

This water heater must **not** be used for pool heating.

### Location:

The water heater should not be installed in small enclosed spaces. For efficient operation, the water heater should be located outdoors or in a space with a volume of at least 200 cubic metres. See page iv for Clearance requirements.

Ensure the compliance plate and associated warnings are clearly visible.

The water heater must be accessible without the use of a ladder or scaffold. Adequate clearance must be available for service to the electrical cover, refrigeration components, controller, relief valve and sacrificial anodes.

Avoid positioning the water heater near bedrooms or neighbours' bedrooms as the water heater may operate during the night.

The water heater should be located as close as possible to the most frequently used hot water outlet.

### Circulated Hot Water Systems:

This water heater should not be installed as part of a circulated hot water flow and return system.

If a circulated flow and return system is required, Dux recommends that a backup electric storage water heater is installed in the recirculation line.

Please consult Dux After Sales and Service for advice if required.



## Important Safety Information

### Water Heater Support:

The water heater must be installed on a flat, solid supporting surface. The pipework must not be used to support the water heater.

Where the water heater is subjected to wet conditions, a plinth should be installed under the water heater.

A properly drained safe tray must be installed where property damage could occur from water spillage. Refer to AS/NZS 3500.4 for further information.

### Clearances:

Allow at least 300 mm clearance above, 500mm clearance on the fan side, 300mm clearance on the evaporator side and 50 mm clearance at the back of the water heater. If possible, allow 500 mm above the water heater to provide clearance to change the anodes through the top cover. Refer to Specifications on page 5.

Make sure there are no obstructions placed around the water heater to ensure adequate air flow.

See diagrams below.

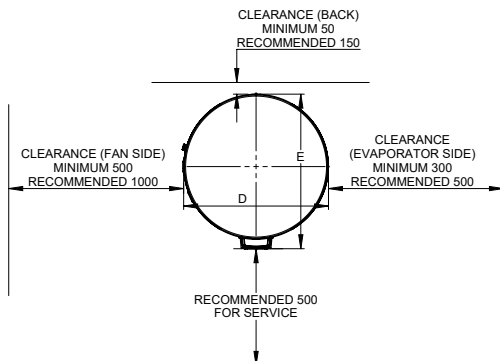

### Transport and Handling:

When moving the water heater, it must be kept in a vertical orientation at all times.

**Never tilt the water heater more than 45° from vertical.**

Tilting beyond 45° will severely affect the operation of the water heater and may void the warranty on the refrigeration components.

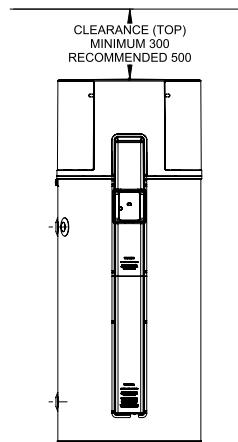



# Contents

Important Safety Information	i
Installation Requirements	iii
Plumbing Connections	3
Specifications	5
Filling and Draining	6
Electrical Connection	7
Wiring Diagram	8
Commissioning	9
Principle of Operation	10
Heat Pump Control Options	11
Dux Heat Pump App	12
System Maintenance	13
Considering a Service Call?	15
Warranty	17



## Plumbing Connections

### Water Supply:

This water heater has been manufactured to suit the water conditions of most Australian and New Zealand metropolitan supplies.

Please note certain water supplies can have a detrimental effect on the water heater and its life expectancy. If you are unsure about the water supply, you can obtain information from the local water supply authority.

The water heater is designed for use in areas where the Total Dissolved Solids (TDS) content of the water supply is less than 2500 mg/L. The Tank Failure Warranty does not apply in areas where the TDS exceeds 2500 mg/L.

In areas where the TDS exceeds 600 mg/L, it is possible the magnesium alloy anode (supplied in standard water heaters) may become over-reactive. To alleviate this, a hard water model is recommended, or the magnesium alloy anode should be replaced with an aluminium alloy anode. Aluminium alloy anodes are available from your local Dux Supplier.

The pH level of water supply should be between 6.5 to 9.5. Outside of this range,

warranty is void.

Water can also be very corrosive, the measure of this is the saturation index. If the water saturation index is greater than 0.40, an expansion control valve should be fitted.

Warranty does not apply if the Saturation Index (LSI) is less than -1.0 or greater than +0.8. LSI figures stated above are calculated with a water temperature of 80°C. Please consult Dux After Sales and Service for advice if required.

### Cold Water Connection:

The water heater is intended to be permanently connected to the water supply main, and not connected by a hose-set.

An approved isolating valve, non-return valve, line strainer (optional but recommended) and union must be fitted between the water supply main and a RP $\frac{3}{4}$ " (DN20) socket marked "INLET" at the bottom of the water heater. See the diagram below for details.

All fittings must be approved by the relevant Authority. Plastic pipes or fittings shall not be used between the isolating valve and the inlet.

### Cold Water Connection Diagram:

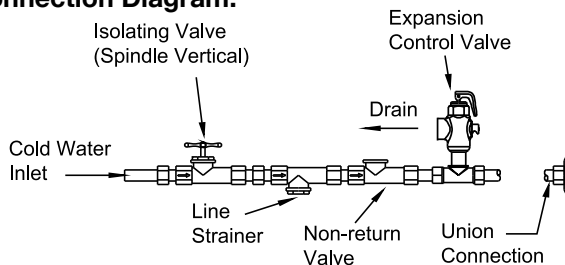

Note: a combined isolating valve/non-return valve/line strainer may be used.

The expansion control valve is only required where local regulations demand, although it is recommended in areas where the water saturation index is greater than 0.40.



# Plumbing Connections

## Water Supply Pressure:

This water heater is designed for direct connection to water supply pressures of up to **800 kPa**.

Where the mains pressure can exceed or fluctuate beyond this pressure, a pressure reducing valve must be fitted in the cold water inlet supply.

**Note for New Zealand, South Australia and Western Australia:** It is a requirement in these locations that an expansion control valve be fitted on the cold water supply line between the non-return valve and the water heater.

## Hot Water Connection:

The hot water pipe can be connected to the RP $\frac{3}{4}$ "(DN20) socket marked "OUTLET" at the top of the water heater.

It is recommended that all hot water pipes are insulated. Hot water pipes installed outdoors should be insulated with UV stabilised insulation.

Plastic pipes or fittings shall not be used within 1 metre of the outlet although they may be used downstream of a temperature control valve. Refer to AS/NZS 3500.4 for further details.

## Temperature Protection:

Water heaters can produce very hot water. To reduce the risk of scald injury, it is mandatory under the requirements of AS/NZS 3500.4 that an approved temperature control device is fitted to the hot water supply to outlets used primarily for personal hygiene. This device should be checked at regular intervals to ensure its operation and settings remain correct.

We recommend using a high performance tempering valve.

## Relief Valve:

The Pressure & Temperature Relief (PTR) Valve

is supplied inside the electrical cover of the water heater. Instructions on how to remove the electrical cover can be found on page 7. Discard the packaging containing the PTR valve.

## **The PTR Valve rating is 1,000 kPa.**

The PTR Valve rating is also shown on the compliance plate. The PTR Valve must be installed directly into the RP $\frac{1}{2}$ "(DN15) socket marked "RELIEF VALVE" at the top of the water heater. Ensure that a sealing material is applied to the PTR Valve to prevent water leaks.

The PTR Valve and its drain line must not be sealed or blocked.

The PTR Valve is not intended to enable connection of the water heater to supplementary energy sources such as solar panels or slow combustion stoves. Refer to AS/NZS 3500.4 for guidance on these types of installations.

It is normal for the valve to leak a small amount of water during heating cycles.

## Relief Valve Drain Line:

The drain line from the PTR Valve must be made of copper and run in accordance with the requirements of AS/NZS 3500.4. It must be installed in a continuously downward direction in a frost free environment.

A separate drain line must be run for this valve. The drain line must not be directly connected to any other copper piping.

## Condensate Drain Line:

A condensate drain point is located on the side of the water heater near the hot water outlet. A drain line must be connected to this point and run so that it discharges clear of the water heater.

Apply at least six layers of plumbing tape on the condensate drain threads before installing the  $\frac{3}{4}$ " fitting. Fittings are only supposed



# Specifications

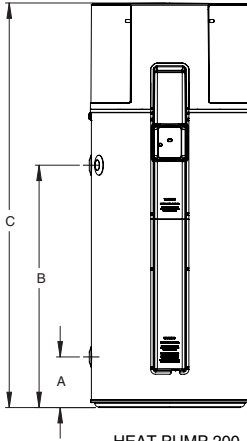

HEAT PUMP 200

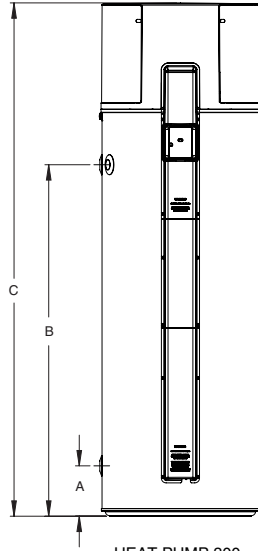
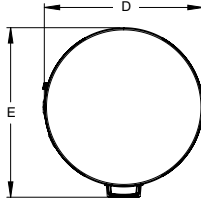

HEAT PUMP 300

### Nominal Dimensions (mm)

Model	200DHA20/20P	300DHA20/20P
Inlet Height (A)	200	200
Outlet Height (B)	950	1375
Total Height (C)	1580	2005
Total Diameter (D)	620	620
Total Depth including Cover (E)	665	665

### Specifications

Model	200DHA20	200DHA20P	300DHA20	300DHA20P
Storage Capacity (L)	202.5	202.5	287	287
Rated Energy Input (kW)	2.5	1.9	2.5	1.9
Max Current (A)	12	10	12	10
Electric Element Rating (W)	1800	1200	1800	1200
Refrigerant Type / Mass (g)	R134a / 670		R134a / 670	
Net Weight (kg)	90		125	
Max. Refrigerant Circuit Pressure (kPa)	2600			
Relief Valve Rating	1000kPa/10kW			



## Filling and Draining

### Filling the Water Heater:

The water heater must be filled with water before turning on the electrical supply.

1. Open all hot water taps.
2. Open the isolating valve at the cold water inlet slowly and allow the water heater to fill until water flows through the system.
3. Close each hot water tap after the air is expelled from its line.
4. Open the Pressure & Temperature Relief Valve for approximately 10 seconds by lifting the easing lever on the valve. Confirm water is relieved to waste through the relief valve drain pipe.
5. Lower the lever gently and check it closes correctly.

### Draining the Water Heater:

1. Turn off the electricity supply to the water heater.
2. Turn off the cold water supply to the water heater at the isolating valve.
3. Gently operate the easing lever on the Pressure & Temperature Relief (PTR) Valve to release the pressure in the water heater.
4. Disconnect the cold water inlet union and attach a drain hose to the water heater.
5. Gently operate the easing lever on the PTR Valve to let air into the water heater and allow water to escape through the hose.



## Electrical Connection

### **General:**

This water heater is designed for single phase 230-240V a.c. supply only. The electrical connection must comply with Local Supply Authority Regulations and AS/NZS 3000.

Connection of the electrical wiring must only be carried out by a licensed tradesperson.

The water heater has been designed for connection to a continuous supply tariff or a suitable extended controlled load tariff (such as Tariff 33 in QLD, or Off-Peak 2 in NSW). Contact Dux After Sales and Service if required.

For hardwired models, a set of terminals and a conduit entry is provided to make permanent connection to fixed wiring.

Connections are to be made at the terminal block under the water heater electrical cover. A means for disconnection must be incorporated in the fixed wiring in accordance with the Wiring Rules.

Plug-in models are supplied with a power cord to plug into a 10A GPO.

It is highly recommended to add means of cable protection to the power cord to offer protection from gardening equipments, vermin etc.

### **Removing the Electrical Cover:**

Before removing the electrical cover, ensure the electrical power supply is safely isolated.

The electrical cover is removed by undoing the screws attaching the bottom cover and sliding the cover downwards to disengage the top edge.

### **Connections (For hardwired models):**

The conduit entry is a pre-punched hole designed to accept a 20 mm conduit gland. It is located adjacent to the terminal block.

To prevent damage to the wiring, the conduit entry must be fitted with a gland prior to feeding the wiring through the hole. Ensure the conduit entry is sealed correctly.

Connect the active and neutral wires to the terminal block and the earth wire to the earth tab (located on the right hand side).

### **Replacing the Electrical Cover:**

1. Ensure the terminal block mounting plate is horizontal.
2. Slide the cover up, ensuring the top edge engages under the case.
3. Swing the cover down until the bottom edge contacts the case. Ensure the terminal block mounting plate is below the pins located inside the cover.
4. Refit and tighten both screws in the cover.

***Ensure the water heater is filled with water before turning on the electricity supply.***

***Warning- Do not replace the heating element with one of higher heating capacity.***



# Wiring Diagram

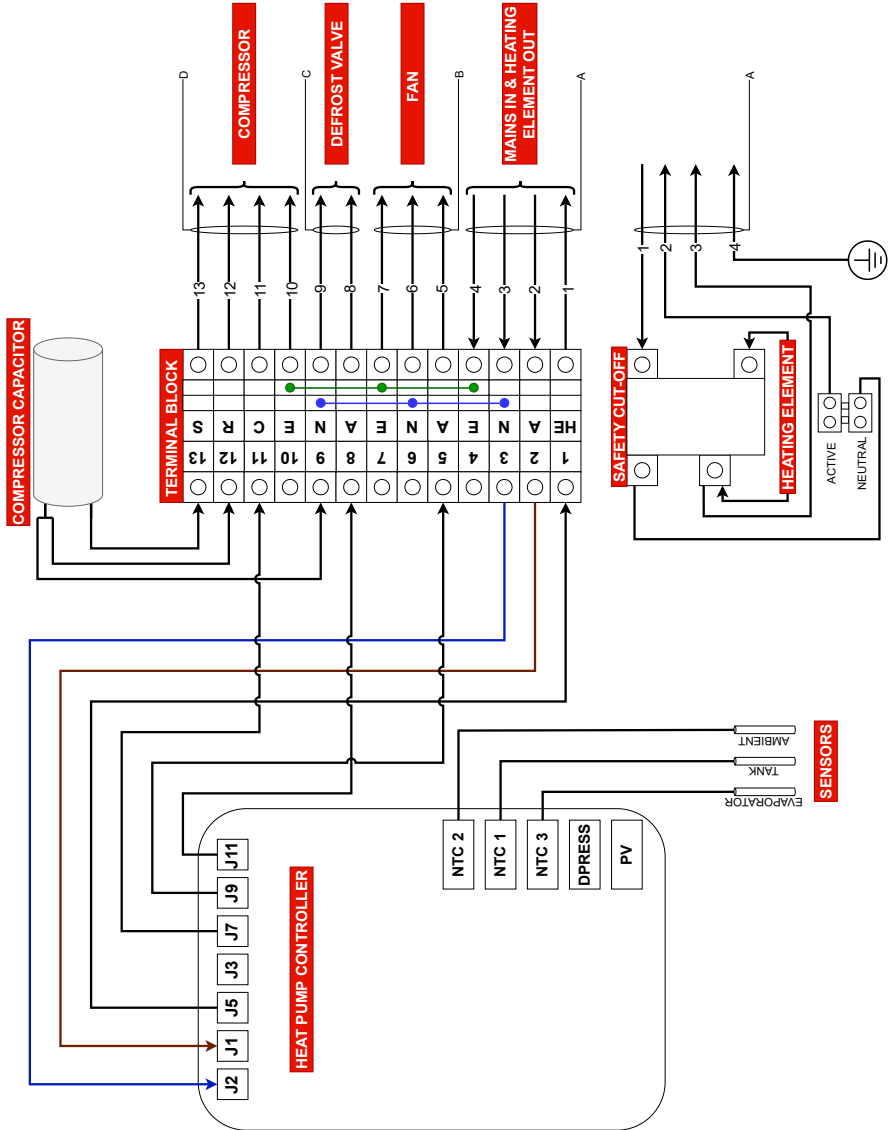



## Commissioning

### Initial Operation:

1. Completely fill the water heater with water before turning on the electrical supply. This can be done by opening all hot water outlets in the house and opening the inlet valves to the heater.
2. Turn on the electrical supply.
3. The light above "AUTO" on the controller will light up.
4. The water heater will start heating within 30 seconds of turning ON the electrical supply.
5. You may choose to press the BOOST button on the controller to accelerate the heating for the first heating cycle. Depending on the ambient conditions, both the heat pump and the element will work to heat the water until the tank is hot. The water heater will return back to the default AUTO mode after one BOOST cycle.
6. To access more functions, use the Dux HP App available on Android and iOS.





## Principle of Operation

### Principle of Operation:

A heat pump storage water heater works in a similar way to a reverse cycle air conditioner. Heat is extracted from the outside air and transferred to the water in the storage tank. It does not need to be located in direct sunlight to work.

A heat pump storage water heater can efficiently produce hot water on cloudy and overcast days as well as during the night.

The length of time that the water heater will operate each day will vary depending on the amount of hot water being used and the ambient temperature and humidity.

Generally, the water heater will run longer in winter and at night when the air is cooler due to less heat energy in the air to absorb.

The controller monitors the water temperature and the ambient air temperature. Providing the ambient conditions are suitable, when the water temperature drops, the controller starts the heat pump module to begin heating the water.

### Freeze Protection

The water heater is equipped with an active-defrost function which automatically melts ice formed on the evaporator coil during cold ambient conditions.

The water heater also has an anti-freeze function which prevents the water in the tank from icing up during vacation mode.

Damage caused by freezing is not covered by the warranty when the water heater is not connected to power.

**WARNING:** Power must be available to the water heater at all times for the anti-freeze function to work.



# Heat Pump Control Options

The water heater can be programmed to run in various modes based on the requirements of the user. The following are the various modes and features available for the water heater. Some of these modes are only available when using the Dux HP App.

## MODES

### Auto

This is the default mode for the water heater and will heat the tank to 60°C. In this mode, the heat pump system will be used to heat the water when the ambient temperature is within -6°C to 45°C. Outside this ambient temperature range, the backup heating element will be used to heat the water.

### Eco

In this mode, only the heat pump system can operate to heat the water. The backup heating element will not operate to heat water and may only be used to prevent freezing of water in the tank. It is recommended to use this mode only when the ambient temperature is expected to be within -6°C to 45°C.

### Boost

In this mode, both the heating element and heat pump system will operate together to heat the water. This mode can be used to reduce the heating time of the water heater. The BOOST function will only operate for one heating cycle after which the water heater will return back to the previous mode.

### Holiday

This mode can be used if the water heater is not expected to be used for a long duration. The water temperature in the tank is kept above 10°C to avoid any risk of freezing.

### Scheduling

The water heater can be scheduled to operate only at particular times of the day using the "Weekly programming" option in the Dux HP App. Please note that scheduling the water heater to run only at particular times of the day increases the risk of running out of hot water.

If you run out, you will need to schedule additional hours in which the water heater can heat. As the heating rate is slower in cold ambient conditions, you are more likely to experience this during the winter months.

## TEMPERATURE SETTINGS

The maximum recommended thermostat setting for the water heater is 60°C.

The thermostat settings for the heating element is factory set and must not be changed.

Adjustment of the thermostat for the electric heating element may lead to incorrect operation of the heat pump system.



## Dux HP Smartphone App

The Dux HP App gives you more control over the operation of the water heater.

Easily program your water heater to run in various modes based on the hot water needs. The Dux HP App can enable scheduling of the heat pump to operate on certain days and times.

This provides additional flexibility to boost your hot water output.

See page 11 for modes.

The App can be downloaded from Google Play Store or Apple App Store; or visit [www.dux.com.au/duxhpapp](http://www.dux.com.au/duxhpapp) to download or scan the QR code below.

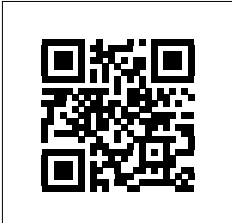



# Installation and Owner's Manual – Ecosmart Heat Pump System Maintenance

Regular servicing will help to extend the life of the water heater, and keep it operating safely and efficiently.

Your water heater warranty is not conditional on completing the regular servicing recommended in this manual.

The conditions applying to your water heater warranty are set out on page 17 of this manual.

## **Six Month Service:**

This service may be carried out by the owner.

1. Stand clear of the Pressure & Temperature Relief (PTR) Valve drain pipe outlet.
2. Open the PTR Valve for approximately 10 seconds by lifting the easing lever on the valve. Confirm water discharges to waste through the drain pipe.
3. Lower the easing lever gently and check it closes correctly.
4. Repeat the above process for the expansion control valve (if installed).
5. Check that the grill on top of the water heater and the louvres are free of debris or other obstructions.

Other than this, personally inspecting or servicing any part of the water heater is not recommended.

## **Five Year Service:**

This service should only be carried out by a licensed tradesperson. We recommend your local Dux Service Agent.

In locations where the water has Total Dissolved Solids (TDS) exceeding 600 mg/L, this service is recommended every 3 years.

This service should include the following:

- Replace the PTR Valve.
- Replace both anodes.
- Inspect and flush the expansion control valve (if installed).
- Clean any debris or residue from the condensate gutter and confirm that the condensate drain line is clear.
- Clean any dust or build up from the evaporator and louvres.
- Clean the fan blades and grill.

Drain and flush the water heater.

Replacement parts are available from your local Dux supplier.



# Installation and Owner's Manual – Ecosmart Heat Pump System Maintenance

## Anode Replacement:

The water heater is equipped with two anode rods.

Follow these steps to replace the anode rods;

1. Ensure that any electrical supply to the water heater is disconnected.
2. Close the isolating valve on the cold-water inlet and release any pressure in the water heater by lifting the lever on the PTR valve.
3. Remove the front cover holding the controller, by removing the screws holding it against the case and pulling it down while simultaneously lifting the bottom of the cover away from the heater. Leave it hanging. Please be careful not to disconnect the wiring connections.
4. Remove the grills on both sides by removing the 2 screws on the top of each grill and pulling the grill out while simultaneously lifting it to disengage the bottom tabs.
5. Remove the 6 screws (3 on each side) holding the top enclosure and slide it up to disengage from the evaporator coil.
6. Remove the 2 anodes using a 1-1/16" socket.
7. Install the new anodes and tighten.
8. Open the cold-water isolating valve and ensure that there is no water leak from the anode connection.
9. Re-install the top enclosure. Ensure that wires are not pinched when doing so. Ensure that the ambient sensor is not dislodged from the top enclosure.
10. Re-install the grills.
11. Re-install the front cover. Ensure that wires are not pinched when doing so.
12. Turn On the electricity supply to the water heater.

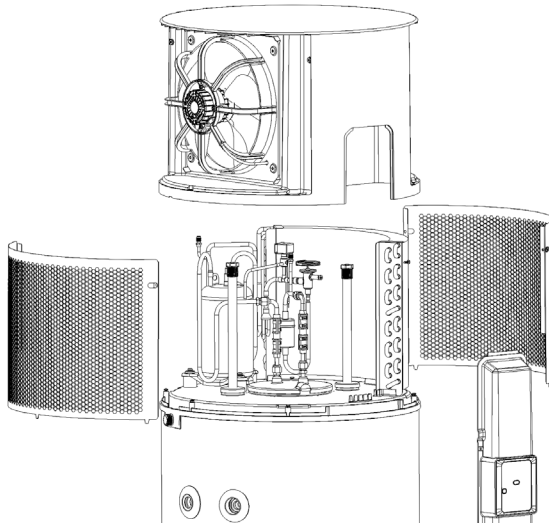



## Considering a Service Call?

Please review this section. Although there are no user serviceable components in the water heater, the information contained in this section may enable you to avoid the cost of a service call.

***Please do not remove any covers or attempt to make any adjustments.***

### **Water Discharge from Condensation Drain Line:**

Water may be expected to drain from the Condensate Drain Line when the water heater is operating. This is similar to the condensation produced by an air conditioner. The amount of condensation produced will depend on ambient conditions such as temperature and humidity.

### **No Hot Water:**

Ensure the power supply circuit breaker has not "tripped". If the water heater is connected to a controlled load tariff, ensure this is operating correctly.

### **Error Detection using Dux HP App:**

Check the Dux HP App to ensure it is in an appropriate heating mode, and / or for any indication of errors. The Dux HP App will indicate an error if the heat pump is continuously in operation for more than 24 hours. It will also indicate other errors like sensor failure.



## Considering a Service Call?

### High Energy Bills or Insufficient Hot Water:

- Often the hot water usage of showers, washing machines and dishwashers can be under estimated. Review these appliances to determine if the daily usage is greater than the capability of the water heater.
- If necessary check the shower flow rates with a bucket, measuring the amount of water used over a period of time. If it is not possible to adjust water usage patterns, an inexpensive flow control valve can easily be fitted to the shower outlet.
- Is the water heater the correct size for the requirements? Sizing details are available from your Dux supplier.
- Check that the grills on the sides of the water heater are free of debris or other obstructions.
- The water heater may take longer to reheat during the night as the air is usually cooler. It is possible that the water heater may not fully recover from a period of heavy usage during the previous day. Consider using the BOOST mode to reheat the water faster.
- Is there a leaking hot water pipe or dripping hot water tap? A small leak can waste a large quantity of hot water. Replace faulty tap washers and arrange for your plumber to rectify any leaking pipe work.

- Is the Pressure & Temperature Relief Valve discharging too much water? See below.

### Continuous Trickle of Water from Pressure & Temperature Relief (PTR) Valve:

This is most likely due to a build up of foreign matter. In this case, try gently raising the easing lever on the PTR Valve for a few seconds, then release gently.

This may dislodge a small particle of foreign matter and rectify the fault.

### Water Discharge from PTR Valve:

It is not unusual for a small quantity of water to discharge during the heating of water in the storage tank. The amount of discharge will depend on hot water usage and the size of the storage tank.

As a guide, it will discharge about 2% of the volume of the water heated.

Continuous leakage of water from the PTR Valve may indicate a problem with the water heater. Turn off the water heater and contact Dux After Sales and Service.

***If after reviewing the information contained in this section, the problem has not been identified, please contact Dux After Sales and Service.***



# Installation and Owner’s Manual – Ecosmart Heat Pump Warranty

## Dux Ecosmart Heat Pump Water Heater - Warranty Summary:

Your water heater is specified with a warranty as set out in the table below.

The fault must appear within the defined time period, which commences from the date of installation (or manufacturing date of the unit if proof of the date of installation is not available) in order to be covered.

Dux Ecosmart Heat Pump Water Heater Warranty <sup>#</sup>		Tank Warranty*	Refrigeration Component <sup>1</sup> Warranty	Other Components <sup>2</sup> Warranty
<b>Single Family Dwelling</b>	<b>Parts</b>	7 years	3 years	1 year
	<b>Labour</b>	3 years	3 years	1 year
<b>All Other Applications</b>	<b>Parts</b>	3 years	1 year	1 year
	<b>Labour</b>	1 year	1 year	1 year

(1) Refrigeration Components include but are not limited to: compressor, condenser, expansion valve, heat exchanger, evaporator and associated pipe work. (2) Other Components include but are not limited to: sensors, thermostats, valves, electric heating elements, anodes.\*Inner Storage Cylinder.

The benefits provided to you by this warranty are in addition to any other rights and remedies available to you under the Australian Consumer Law or the Consumer Guarantees Act 1993 (NZ).

#Where an incentive is being applied for under the Victorian Energy Upgrades (VEU) Program, or through the Solar Victoria's Solar Home Program, a separate warranty applies. See page 18.

### Other Components<sup>2</sup> Warranty:

Dux Manufacturing Limited (“Dux”) warrants against defects in the water heater arising from faulty materials or workmanship.

During the period (as specified in the table above), Dux will repair or replace any failed component<sup>2</sup> free of charge including reasonable labour costs incurred during normal business working hours.

### Refrigeration Component<sup>1</sup> Warranty:

Dux warrants against failure of refrigeration components<sup>1</sup> arising from faulty materials or workmanship (as specified in the table above).

During this period of coverage Dux will repair or replace any failed refrigeration component free of charge including reasonable labour costs incurred during normal business working hours.

### Tank Failure Warranty:

Dux warrants against failure of the storage tank, in accordance with its application (as specified in the table above). Conditions apply.

During the period of coverage (as specified in the table above), Dux will repair or replace the tank free of charge including reasonable labour costs incurred during normal business working hours.

Installation and other labour costs are the responsibility of the owner if the water heater is outside the labour warranty period.



## Warranty

### **Victorian Energy Upgrades (VEU) Warranty:**

Without limiting the periods shown in the table on page 17, a 5 year product warranty applies where Victorian Energy Efficiency Certificates (VEECs) have been created for an eligible water heater installation activity (activity 1, 3 or 44) when installed from 1st February 2025. For further details call Dux After Sales and Service on 1300 365 115. Proof of VEEC assignment is required to be provided at the time of booking the service call.

### **Solar Victoria's Solar Home Program Warranty:**

Without limiting the periods shown in the table on page 17, a 5 year 'Whole of Product' warranty applies where a rebate has been received under Solar Victoria's Solar Homes Program for a water heater installed from 1st July 2023. For further details call Dux After Sales and Service on 1300 365 115. Rebate proof of receipt is required to be provided at the time of booking the service call.

### **Warranty Conditions:**

The warranty only applies to the water heater itself and the components supplied with the water heater by Dux. The warranty does not cover components supplied by others, including the installer.

Dux may reject a claim under this warranty in its sole discretion if a third party solar diverter is connected to the water heater.

The tank failure warranty does not apply if the water heater has been connected to a water supply where the Total Dissolved Solids (TDS) content is greater than 2500 mg/L.

For TDS between 600mg/L and 2500 mg/L, a hard water version with Aluminium anodes must be used.

Warranty does not apply for heaters with Magnesium anodes when TDS is greater than 600 mg/L

Warranty also does not apply if the Saturation Index (LSI) is less than -1.0 or greater than +0.8. LSI figures stated above are calculated with a water temperature of 80°C.

These warranties do not apply to defects that are a result of, without limitation, the following:

- failure to install the water heater in accordance with the installation instructions or statutory requirements;
- faulty plumbing or water supply including excessive pressure;
- faulty power supply;
- damage caused by freezing is not covered by the warranty when not connected to power;
- use of the water heater in a manner contrary to this manual or other instructions provided by Dux;
- alterations or repair of the water heater other than by an accredited and licensed service agent or technician;
- accidental damage or abuse;
- where the water heater has been tilted more than 45 degrees from vertical;
- if the water pH is less than 6.5 or greater than 9.5;
- where penetrations damage the heat exchanger coil on the tank, or the inner tank cylinder, warranty will be void.

If the water heater is installed in a position that does not comply with the installation instructions or statutory requirements, then this warranty does not cover major dismantling or removal of cupboards, doors, walls or special equipment and/or excessive labour, at the determination of Dux, to make the water heater accessible for repair or replacement. Where the Dux water heater is located outside the metropolitan area of a capital city and is more than 100km from a Dux office or Dux agent, the Owner will be responsible under the warranty for paying the costs of transporting the water heater and or any component in the water heater to and from an approved Dux agent or Dux office (including any insurance associated with that transport), or paying the travelling time of an approved Dux agent to and from the owners premises.

### **Commencement of Warranty:**

The warranty period commences from the date of installation of the water heater. Where proof of the date of installation is not available, the warranty period commences on the date of manufacture of the water heater. This is shown on the compliance plate on the outside of the water heater.



## Warranty

The replacement of the water heater, or a component of it, under this warranty does not change the warranty commencement date. The original commencement date continues to apply.

### **Exclusion and Limitation of Liability:**

In addition to any other provisions set out in this document and to the maximum extent permitted by any applicable law or regulation, Dux will not be liable for any claim:

1. for consequential loss to any property arising directly or indirectly out of or connected to the supply or installation of the water heater. This includes but is not limited to furnishings, carpets, foundations, housing effects and buildings.
2. for any direct or indirect economic or financial loss of any nature.
3. arising out of or connected to a water heater that has been uninstalled, resold or moved from its original installation location.
4. arising out of or connected to any misuse, or other use, installation or maintenance that is not in accordance with the procedures and requirements set out in this document.

To the extent permitted by law the liability of Dux shall be limited to the cost of the repair or replacement of the water heater.

### **The Australian Consumer Law (“ACL”):**

*Our goods come with guarantees that cannot be excluded under the Australian Consumer Law. You are entitled to a replacement or refund for a major failure and compensation for any other reasonably foreseeable loss or damage. You are also entitled to have the goods repaired or replaced if the goods fail to be of acceptable quality and the failure does not amount to a major failure.*

If Dux fails to meet a guarantee under the ACL, your remedy for such failure may be limited to any one or more of the following:

- replacement of the water heater;
- repair of the water heater;
- refunding the cost of the water heater;
- payment of the reasonable costs of having the water heater repaired;
- payment in respect of the reduced value of the water heater.

### **The Consumer Guarantees Act 1993 (New Zealand):**

*Our goods come with guarantees that cannot be excluded under the Consumer Guarantees Act 1993 (New Zealand). If the goods fail to comply with the applicable guarantees set out under the Consumer Guarantees Act 1993 (New Zealand) being the guarantee as to acceptable quality, the guarantee as to correspondence with description or the guarantee as to repair and parts, or if the goods fail to comply with any express guarantee given by Dux, then you are entitled to a replacement or refund and for compensation for any other reasonably foreseeable loss or damage.*

### **How to Make a Warranty Claim:**

Warranty claims can be placed by completing the following steps:

- Contact Dux on one of the numbers listed below.
- Select the “Service” option followed by the “Hot Water” option.
- Provide the serial number and model number of the water heater. This can be found on the compliance plate on the outside of the water heater.
- Provide your full name, address & contact number.
- Provide proof of date of installation for warranty to commence from that date, rather than from the date of manufacture. See Commencement of Warranty on page 18.

Please note, if the defect or fault is not covered by the warranty or guarantee, you will be responsible for the costs incurred by the service agent or technician.

Dux service calls can only be scheduled during business hours (AEST) Monday to Friday and are not available on weekends & public holidays.

### **Contact Details:**

Dux Manufacturing Limited  
Lackey Road, Moss Vale, NSW, 2577, Australia  
1300 365 115 (Australia)  
0800 729 389 (New Zealand)  
Email: [duxaftersales@dux.com.au](mailto:duxaftersales@dux.com.au)



For advice, repairs and service, call:

1300 365 115 (Australia)

0800 729 389 (New Zealand)

**Please Register Your Water Heater**



Please take a moment to fill out your details for warranty registration at:

[www.dux.com.au/warranty](http://www.dux.com.au/warranty)

or use your smartphone to scan this code:



This will ensure all your current details are registered with us for prompt warranty service if required.

To view our privacy policy please visit <http://www.dux.com.au/p/privacy>

**Date of Installation:** .....

**Installer's Name:** .....

**Installer's Company:** .....

**Installer's Licence No:** .....

**Installer's Signature:** .....

Serial Number