



Installation and Owner's Manual

IMPORTANT INFORMATION

Failure to follow these instructions may affect the Warranty

ecosmart[®]

Heat Pump Water Heater

Model: 200DHC25, 200DHC25P,
300DHC25, 300DHC25P

Note: A 'H' at the end of the model number indicates that the water heater is fitted with a hard-water anode.

Note: To connect the heat pump to the Smart Life App, you must have power supply and Wi-Fi reception at the water heater's location.



Installation Details

Owner's Information

Warranty

For advice, repairs and service, call:

1300 365 115 (Australia)

0800 729 389 (New Zealand)



Carefully remove all packaging and transit protection from the heater before installation. Dispose of the packaging responsibly using re-cycling facilities where they exist.

Specifications and materials may change without notice.
Effective for Ecosmart[®] water heaters manufactured and sold after 1st July 2025.



Important Safety Information

WARNING – THIS APPLIANCE MAY DELIVER WATER AT HIGH TEMPERATURE. REFER TO THE PLUMBING CODE OF AUSTRALIA (PCA), LOCAL REQUIREMENTS AND INSTALLATION INSTRUCTIONS TO DETERMINE IF ADDITIONAL DELIVERY TEMPERATURE CONTROL IS REQUIRED.

WARNING – FOR CONTINUED SAFETY OF THIS APPLIANCE IT MUST BE INSTALLED, OPERATED AND MAINTAINED IN ACCORDANCE WITH THE MANUFACTURER'S INSTRUCTIONS.

This water heater is not intended for use by persons (including children) with reduced physical, sensory or mental capabilities, or lack of experience and knowledge, unless they have been given supervision or instruction concerning use of the water heater by a person responsible for their safety.

Children should be supervised to ensure they do not interfere with the water heater.

Ensure animals are supervised so they do not interfere with the water heater..



THIS APPLIANCE USES R290 (PROPANE) REFRIGERANT, WHICH IS A FLAMMABLE GAS CLASS 3 ACCORDING TO ISO 817 AND MUST BE HANDLED BY A REFRIGERATION MECHANIC WITH APPROPRIATE AUSTRALIAN REFRIGERANT HANDLING LICENCE.

WARNING: RISK OF FIRE / FLAMMABLE MATERIAL. IF THE REFRIGERANT IS LEAKED, TOGETHER WITH AN EXTERNAL IGNITIONS SOURCE, THERE IS A POSSIBILITY OF IGNITION.

DO NOT STORE CHEMICALS OR FLAMMABLE MATERIALS, OR SPRAY AEROSOLS NEAR THIS WATER HEATER.

DO NOT STORE ANY COMBUSTIBLE MATERIAL NEAR THIS WATER HEATER.

DO NOT MODIFY THIS WATER HEATER.

DO NOT OPERATE THE WATER HEATER WITH ANY PANELS OR COVERS REMOVED.

DO NOT USE MEANS TO ACCELERATE THE DEFROSTING PROCESS OR TO CLEAN, OTHER THAN THOSE RECOMMENDED BY THE MANUFACTURER.

THE APPLIANCE SHALL BE STORED IN A ROOM WITHOUT CONTINUOUSLY OPERATING IGNITION SOURCES.

FOR EXAMPLE, OPEN FLAMES, AN OPERATING GAS APPLIANCE OR AN OPERATING ELECTRIC HEATER.

DO NOT PIERCE OR BURN.

BE AWARE THAT REFRIGERANTS MAY NOT CONTAIN AN ODOUR.

DO NOT INSERT YOUR FINGER, A STICK, OR OTHER OBJECTS INTO THE AIR INLET & OUTLET GRILLS. THIS MAY CAUSE INJURY, SINCE THE FAN INSIDE ROTATES AT HIGH SPEEDS DURING OPERATION.

WARNING – IF THE WATER HEATER IS NOT USED FOR TWO WEEKS OR MORE, A QUANTITY OF HYDROGEN (WHICH IS HIGHLY FLAMMABLE) MAY ACCUMULATE INSIDE THE WATER HEATER TANK. TO DISSIPATE THIS GAS SAFELY IT IS RECOMMENDED THAT A HOT TAP BE TURNED ON FOR SEVERAL



Important Safety Information

MINUTES AT A SINK, BASIN OR BATH, BUT NOT A DISHWASHER, CLOTHES WASHER OR OTHER APPLIANCE. DURING THIS PROCEDURE THERE MUST BE NO SMOKING, OPEN FLAME OR ANY OTHER ELECTRICAL APPLIANCE OPERATING NEARBY. IF HYDROGEN IS DISCHARGED THROUGH THE TAP IT WILL PROBABLY MAKE A SOUND SIMILAR TO AIR ESCAPING.

RELIEF VALVE:

The Pressure & Temperature Relief (PTR) Valve must be installed directly into the RP $\frac{1}{2}$ " (DN15) socket marked 'RELIEF VALVE'.

The PTR Valve rating is 1,000 kPa and 10 kW.

The valve must not be tampered with or removed. The water heater must not be operated unless this valve is fitted and in working order.

The drain line from the PTR Valve must be installed in a continuously downward direction in a frost free environment. Take care not to overtighten the drain connection

The PTR Valve is to be operated regularly to remove lime deposits and to verify it is not blocked. The drain line fitted to the PTR Valve must be left open to the atmosphere.

DANGER: FAILURE TO OPERATE THE PTR VALVE EASING LEVER AT LEAST ONCE EVERY SIX MONTHS MAY RESULT IN THE WATER HEATER EXPLODING. CONTINUOUS LEAKAGE OF WATER FROM THE VALVE MAY INDICATE A PROBLEM WITH THE WATER HEATER.

The PTR Valve should be checked by a licensed tradesperson for adequate performance, or replaced at intervals not

exceeding 5 years, or less in areas where local regulations apply.

It is normal for water to drip from the drain line fitted to the PTR Valve during heating cycles.

Continuous leakage of water from the PTR Valve may be caused by excessive water supply pressure, a faulty PTR Valve or a faulty thermostat.

Turn off the water heater and consult Dux After Sales and Service for advice if required.

OVER-TEMPERATURE ENERGY CUT-OUT:

The operation of the over-temperature energy cut-out on the thermostat indicates a possibly dangerous situation. Do NOT reset the overtemperature energy cut-out until the water heater has been serviced by a licensed tradesperson.

ELECTRICAL SAFETY:

This water heater is designed for single phase 230 - 240V a.c. supply only. The electrical connection must comply with Local Supply Authority Regulations and AS/NZS 3000 (known as the Wiring Rules). A means for disconnection must be incorporated in the fixed wiring in accordance with the Wiring Rules.

Any electrical covers should be removed only by a licensed tradesperson, and only after the electrical supply to the water heater has been isolated.

When the supply wiring has been connected, ensure the wires are kept lower than the terminal block.

Warning- Do not replace the heating element with one of higher heating capacity.



Important Safety Information

Excess wire is not to be looped close to the thermostat or tank.

In addition to the PTR Valve, the water heater is fitted with an over-temperature energy cut-out.

These devices must not be tampered with or removed. Replacement of these devices must only be carried out by a licensed tradesperson or the manufacturer.

The water heater must not be operated unless these devices are fitted and in working order.

COLD WATER CONNECTION:

The water heater is intended to be permanently connected to the water supply main, and not connected by a hose-set.

This water heater is designed for direct connection to water supply pressures of up to 800 kPa.

Where the mains pressure can exceed or fluctuate beyond this pressure, a pressure reducing valve must be fitted in the cold water inlet supply.

Instructions explaining how the water heater can be drained can be found on page 6.



Important Safety Information

INSTALLATION REQUIREMENTS

General:

This water heater must be installed by a licensed tradesperson, and in accordance with:

- In Australia, the Plumbing Code of Australia (PCA). The products comply with the leadfree requirements of the national construction code, Volume Three;
- In New Zealand, Clause G12 of the New Zealand Building Code (NZBC);
- AS/NZS 3000 Electrical Installations (known as the Australian / New Zealand Wiring Rules); and
- Local authority regulations.

Outside Australia and New Zealand, please refer to local plumbing and building codes and regulations.

Failure to comply with these requirements may affect the warranty.

AS/NZS 3500.4 Plumbing and Drainage - Heated Water Services provides a Deemed to- Satisfy Solution for the PCA and a Verification Method for Clause G12 of the NZBC. Other methods of compliance are available. Dux recommends that installations conform with AS/NZS 3500.4.

Note for Victoria:

This water heater must be installed by a licensed person as required by the Victorian Building Act (1993).

Only a licensed person will provide a compliance certificate, showing that the work complies with all the relevant Standards. Only a licensed person will have insurance protecting their workmanship.

Pool Heating:

This water heater must **not** be used for pool heating.

Location:

The water heater is only suitable for outdoor installation.

See page v for Clearance requirements.

Ensure the compliance plate and associated warnings are clearly visible.

The water heater must be accessible without the use of a ladder or scaffold. Adequate clearance must be available for service to the electrical cover, refrigeration components, controller, relief valve and sacrificial anodes.

Avoid positioning the water heater near bedrooms or neighbours' bedrooms as the water heater may operate during the night.

The water heater should be located as close as possible to the most frequently used hot water outlet.

Circulated Hot Water Systems:

This water heater should not be installed as part of a circulated hot water flow and return system.

If a circulated flow and return system is required, Dux recommends that a backup electric storage water heater is installed in the recirculation line.

Please consult Dux After Sales and Service for advice if required.

Water Heater Support:

The water heater must be installed on a flat, solid supporting surface. The pipework must not be used to support the water heater.

Where the water heater is subjected to wet conditions, a plinth should be installed under the water heater.



Important Safety Information

A properly drained safe tray must be installed where property damage could occur from water spillage. Refer to AS/NZS 3500.4 for further information.

Clearances:

Allow at least 300mm clearance above, 500mm clearance on the fan side, 300mm clearance on the evaporator side and 50mm clearance at the back of the water heater.

If possible, allow 500mm above the water heater to provide clearance to change the anodes through the top cover. Refer to Specifications on page 5.

Make sure there are no obstructions placed around the water heater to ensure adequate air flow.

See diagrams below.

Transport and Handling:

*When moving the water heater, **never tilt the water heater more than 45° from vertical.***

Tilting beyond 45° will severely affect the operation of the water heater and may void the warranty on the refrigeration components.

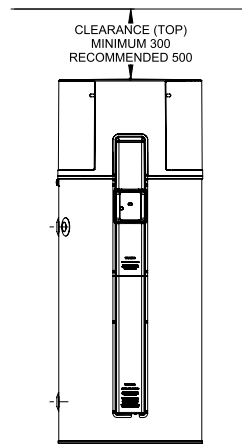
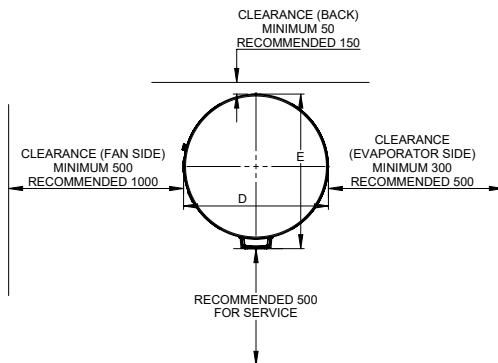



Contents

Important Safety Information	ii
Installation Requirements	v
Plumbing Connections	2
Specifications	5
Filling and Draining	6
Electrical Connection	7
Wiring Diagram	8
Commissioning	9
Modes & Smart Life App	10
Controller Functions	11
Controller Modes	12
Smart Life App settings	14
Principle of Operation	21
System Maintenance	22
Considering a Service Call?	24
Service & Decommissioning	26
Warranty	30

Specifications and materials may change without notice.

Effective for all Ecosmart Heat Pump Water Heaters manufactured and sold after 1st March 2025.



Plumbing Connections

Water Supply:

This water heater has been manufactured to suit the water conditions of most Australian and New Zealand metropolitan supplies.

Please note certain water supplies can have a detrimental effect on the water heater and its life expectancy. If you are unsure about the water supply, you can obtain information from the local water supply authority.

The water heater is designed for use in areas where the Total Dissolved Solids (TDS) content of the water supply is less than 2500mg/L. The Tank Failure Warranty does not apply in areas where the TDS exceeds 2500mg/L.

In areas where the TDS exceeds 600mg/L, it is possible the magnesium alloy anode (supplied in standard water heaters) may become over-reactive.

To alleviate this, a hard water model is recommended, or the magnesium alloy anode should be replaced with an aluminium alloy anode. Aluminium alloy anodes are available from your local Dux Supplier.

The pH level of water supply should be between 6.5 to 9.5. Outside of this range, warranty is void.

Water can also be very corrosive, the measure of this is the saturation index. If the water saturation index is greater than 0.40, an expansion control valve should be fitted.

Warranty does not apply if the Saturation Index (LSI) is less than -1.0 or greater than +0.8. LSI figures stated above are calculated with a water temperature of 80°C.

Please consult Dux After Sales and Service for advice if required.

Cold Water Connection:

The water heater is intended to be permanently connected to the water supply main, and not connected by a hose-set.

An approved isolating valve, non-return valve, line strainer (optional but recommended) and union must be fitted between the water supply main and a RP $\frac{3}{4}$ "(DN20) socket marked 'INLET' at the bottom of the water heater. See the diagram below for details.

All fittings must be approved by the relevant Authority. Plastic pipes or fittings shall not be used between the isolating valve and the inlet.

Cold Water Connection Diagram:

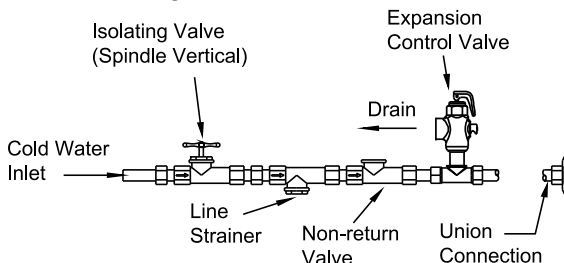

Note: a combined isolating valve/non-return valve/line strainer may be used.

The expansion control valve is only required where local regulations demand, although it is recommended in areas where the water saturation index is greater than 0.40.



Plumbing Connections

Water Supply Pressure:

This water heater is designed for direct connection to water supply pressures of up to **800 kPa**.

Where the mains pressure can exceed or fluctuate beyond this pressure, a pressure reducing valve must be fitted in the cold water inlet supply.

Note for New Zealand, South Australia and Western Australia: It is a requirement in these locations that an expansion control valve be fitted on the cold water supply line between the non-return valve and the water heater.

Hot Water Connection:

The hot water pipe can be connected to the RP $\frac{3}{4}$ "(DN20) socket marked 'OUTLET' at the top of the water heater.

It is recommended that all hot water pipes are insulated. Hot water pipes installed outdoors should be insulated with UV stabilised insulation.

Plastic pipes or fittings shall not be used within 1 metre of the outlet although they may be used downstream of a temperature control valve.

Refer to AS/NZS 3500.4 for further details.

Temperature Protection:

Water heaters can produce very hot water. To reduce the risk of scald injury, it is mandatory under the requirements of AS/NZS 3500.4 that an approved temperature control device is fitted to the hot water supply to outlets used primarily for personal hygiene. This device should be checked at regular intervals to ensure its operation and settings remain correct.

We recommend using a high performance tempering valve.

Relief Valve:

The Pressure & Temperature Relief (PTR) Valve is supplied inside the electrical cover or in a box attached to the water heater. Instructions on how to remove the electrical cover can be found on page 7. Discard the packaging containing the PTR valve.

The PTR Valve rating is 1,000 kPa.

The PTR Valve rating is also shown on the compliance plate. The PTR Valve must be installed directly into the RP $\frac{1}{2}$ "(DN15) socket marked 'RELIEF VALVE' at the top of the water heater. Ensure that a sealing material is applied to the PTR Valve to prevent water leaks.

The PTR Valve and its drain line must not be sealed or blocked.

The PTR Valve is not intended to enable connection of the water heater to supplementary energy sources such as solar panels or slow combustion stoves. Refer to AS/NZS 3500.4 for guidance on these types of installations.

It is normal for the valve to leak a small amount of water during heating cycles.

Relief Valve Drain Line:

The drain line from the PTR Valve must be made of copper and run in accordance with the requirements of AS/NZS 3500.4. It must be installed in a continuously downward direction in a frost free environment.

A separate drain line must be run for this valve. The drain line must not be directly connected to any other copper piping.



Plumbing Connections

Condensate Drain Line:

A condensate drain point is located on the side of the water heater near the hot water outlet.

A drain line must be connected to this point and run so that it discharges clear of the water heater.

The Condensate Drain Line must not be connected to the Relief Valve Drain Line although they may both discharge to the same point.

Apply at least six layers of plumbing tape on the condensate drain threads before installing the 3/4" fitting. Fittings are only supposed to be hand tightened. Do not use any tool to over tighten the fitting. Excessive tightening will damage the threads.



Specifications

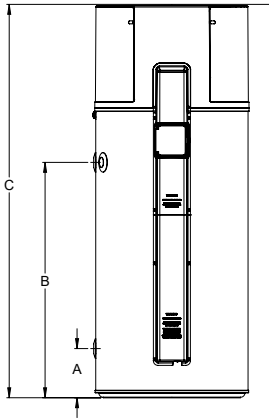

HEAT PUMP 200

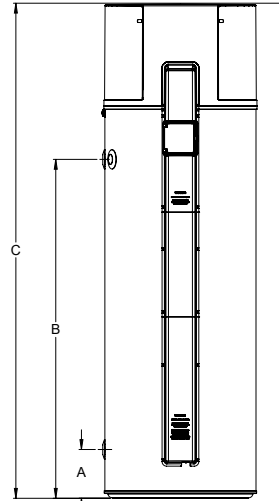
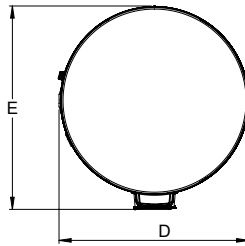

HEAT PUMP 300

Nominal Dimensions (mm)

Model	200DHC25/25P	300DHC25/25P
Inlet Height (A)	200	200
Outlet Height (B)	950	1375
Total Height (C)	1580	2005
Total Diameter (D)	620	620
Total Depth including Cover (E)	665	665

Specifications

Model	200DHC25	200DHC25P	300DHC25	300DHC25P
Storage Capacity (L)	202.5	202.5	287	287
Rated Energy Input (kW)	2.6	2.0	2.6	2.0
Max Current (A)	12.6	10	12.6	10
Electric Element Rating (W)	1800	1200	1800	1200
Refrigerant Type / Mass (g)	R290 / 270		R290 / 290	
Net Weight (kg)	90		125	
Max. Refrigerant Circuit Pressure (kPa)	2600			
Relief Valve Rating	1000kPa/10kW			



Filling and Draining

Filling the Water Heater:

The water heater must be filled with water before turning on the electrical supply.

1. Open all hot water taps.
2. Open the isolating valve at the cold water inlet slowly and allow the water heater to fill until water flows through the system.
3. Close each hot water tap after the air is expelled from its line.
4. Open the Pressure & Temperature Relief Valve for approximately 10 seconds by lifting the easing lever on the valve. Confirm water is relieved to waste through the relief valve drain pipe.
5. Lower the lever gently and check it closes correctly.

Draining the Water Heater:

1. Turn off the electricity supply to the water heater.
2. Turn off the cold water supply to the water heater at the isolating valve.
3. Gently operate the easing lever on the Pressure & Temperature Relief (PTR) Valve to release the pressure in the water heater.
4. Disconnect the cold water inlet union and attach a drain hose to the water heater.
5. Gently operate the easing lever on the PTR Valve to let air into the water heater and allow water to escape through the hose.



Electrical Connection

General:

This water heater is designed for single phase 230-240V a.c. supply only. The electrical connection must comply with Local Supply Authority Regulations and AS/NZS 3000.

Connection of the electrical wiring must only be carried out by a licensed tradesperson.

The water heater has been designed for connection to a continuous supply tariff or a suitable extended controlled load tariff (such as Tariff 33 in QLD, or Off-Peak 2 in NSW).

For hardwired models, a set of terminals and a conduit entry is provided to make permanent connection to fixed wiring.

Connections are to be made at the terminal block under the water heater electrical cover. A means for disconnection must be incorporated in the fixed wiring in accordance with the Wiring Rules.

Plug-in models are supplied with a power cord to plug into a 10A GPO.

It is highly recommended to add means of cable protection to the power cord to offer protection from gardening equipment, vermin etc.

Removing the Electrical Cover:

Before removing the electrical cover, ensure the electrical power supply is safely isolated.

The electrical cover is removed by undoing the screws attaching the bottom cover and sliding the cover downwards to disengage the top edge.

Connections (For hardwired models):

The conduit entry is a pre-punched hole designed to accept a 20 mm conduit gland. It is located adjacent to the terminal block.

To prevent damage to the wiring, the conduit entry must be fitted with a gland prior to feeding the wiring through the hole. Ensure the conduit entry is sealed correctly.

Connect the active and neutral wires to the terminal block and the earth wire to the earth tab (located on the right hand side).

Replacing the Electrical Cover:

1. Ensure the terminal block mounting plate is horizontal.
2. Slide the cover up, ensuring the top edge engages under the case.
3. Swing the cover down until the bottom edge contacts the case. Ensure the terminal block mounting plate is below the pins located inside the cover.
4. Refit and tighten both screws in the cover.









Ensure the water heater is filled with water before turning on the electricity supply.

Warning- Do not replace the heating element with one of higher heating capacity.



Commissioning

Initial Operation:

1. Completely fill the water heater with water before turning on the electrical supply. This can be done by opening all hot water outlets in the house and opening the inlet valves to the heater.
2. Turn on the electrical supply.
3. Press and hold the  button for 5 seconds until the  icon appears on the screen to start the water heater.
4. The display Auto-Locks after one minute of inactivity. To unlock the display, press and hold the  button for 5 seconds.
5. Press the  button to cycle through the modes.
 -  Standard Eco Mode (Heat pump only)
 -  Boost Mode (Heat pump & element)
 -  Holiday Mode (No heating)
6. Press and hold  and  together to activate Wi-Fi pairing and connection to the Smart Life App. The Wi-Fi symbol on the controller display will blink rapidly when the pairing mode is activated.





Modes & Smart Life App

The Ecosmart heat pump has 3 primary modes and one Rescue function to temporarily run the heat pump in the event of a heat pump component failure.

The modes are explained below:

MODES

Eco

This is the primary mode of the water heater. In this mode, the heat pump will heat the tank to 60°C in each heating cycle.

Boost

In the boost mode, both heat pump and heating element will simultaneously heat the water to 60°C. Boost is a 'one-shot' operation and the heat pump will move to ECO mode after one heating cycle in BOOST mode.

Holiday

The heat pump or heating element won't be operational in Holiday mode. The tank will be maintained between 5°C and 10°C to prevent freezing of water in the tank.

Rescue

In addition to these primary modes, a RESCUE function can be chosen (only available from the App) to temporarily run the heating element in case of failure of the heat pump heating system. In Rescue, the heating element will heat the water in the tank to 60°C.

Anti-Legionella protection

In order to prevent the growth of legionella bacteria, more than 45% of water in the tank is heated to 60°C in every heating cycle.

Smart Life App

The Smart Life App gives you more control over the operation of the water heater.

Easily program your water heater to run in various modes based on the hot water needs. Also provides additional flexibility to boost your hot water output.

The App can be downloaded from Google Play Store or Apple App Store; or scan the QR code below.

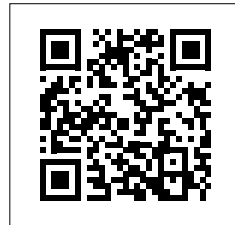



Controller Functions

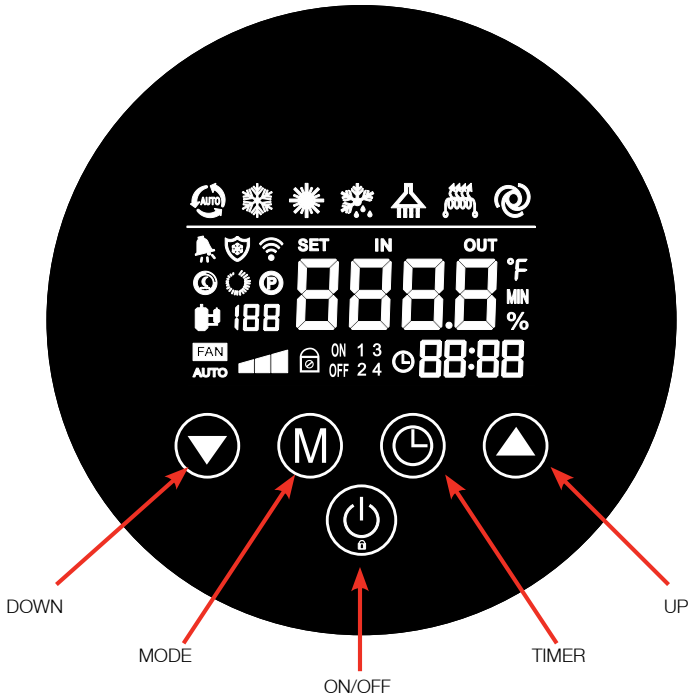



	Indicates heating.
	Indicates defrosting operation.
	Indicates Wi-Fi connection is successful.
	Wi-Fi icon will be solid if connection is stable.
	Wi-Fi icon will flash during pairing and when the connection is unstable.

	Flashes when a fault is reported on the heater.
	Indicates the compressor is running.
	Indicates the fan is running.
	Indicates the rescue mode is enabled [only available via the Smart Life app].
	Indicates the heating element is operating.





Common Modes & Operation



Display Unlocking:

1. Display auto locks after 1 min of inactivity.
2.  will be displayed if controller screen is locked.
3. Press and hold the  button for 5 sec to unlock.

Turn ON the heat pump:



1. Press the  button for 5 seconds to turn the unit ON.
2.  Icon will appear when the unit is ON.

Turn OFF the heat pump:









1. Press the  button for 5 seconds to turn the unit OFF.
2.  Icon will disappear when the unit is OFF.

Changing operation mode:



Press the  button to cycle through different operation modes

-  ECO Mode (Heat Pump only)
-  BOOST Mode (Heat Pump + Element)
-  HOLIDAY Mode (No heating)

Clock setting:

1. Press and hold  +  buttons for 3 seconds to enter clock settings.
2. When the hour digit starts flashing, press  or  to adjust the hours.
3. Press  to set the hour value and continue to adjust the minutes.
4. When minutes digit starts flashing, press  or  to adjust the minutes.
5. Press  to set the minute and exit the clock settings.









Wi-Fi configuring:

1. Press and hold  +  buttons for 3 seconds to enter the pairing mode.
2. The  symbol will flash during the pairing mode and becomes solid once the connection is successful.
3. Use the Smart Life app to connect to the water heater.



Common Modes & Operation

Schedule timer settings:

1. Users can schedule the operating times of the heat pump to operate during times of excess PV generation or cheaper concessional tariffs.
2. There are 3 timer schedules available as shown below. The time is displayed in 24hrs.
 - Timer 1 ON 00:00
 - Timer 1 OFF 00:00
 - Timer 2 ON 00:00
 - Timer 2 OFF 00:00
 - Timer 3 ON 00:00
 - Timer 3 OFF 00:00
3. Press and hold  button for 3 seconds to enter timer settings. The display will show Timer 1 ON 00:00 with flashing hour digits.
4. Press  or  to adjust the hours.
5. Press  to set the hour value and switch to adjusting the minutes.
6. Press  or  to adjust the minutes.
7. Press  to set the minute and enter Timer 1 OFF 00:00.
8. Repeat the steps 4 to 6 to set OFF time for Timer 1.
9. Press  to set the minute and enter Timer 2 ON 00:00.
10. Repeat the steps 4 to 6 to set operating times for Timer 2 & 3.

Cancel ON/OFF Timers settings:

1. Timers are cancelled when both the ON & OFF times are set to same value.
2. An example of cancelled timer 1 shown below
 - Timer 1 ON 00:00
 - Timer 1 OFF 00:00
 - Timer 2 ON 08:00
 - Timer 2 OFF 16:00
 - Timer 3 ON 20:00
 - Timer 3 OFF 23:55



Smart Life App

The Smart Life app gives you additional control over the operation of your heat pump water heater.

To download the Smart Life app, please scan the QR code below.



Alternatively, you can search for “Smart Life” in the App Store or Google Play Store.

After downloading, follow the steps described in the setup guide.

Setup guide

1. Install and open the “Smart Life” App and select “SIGN UP” to create a new account or login to an existing account & skip forward to the pairing process.

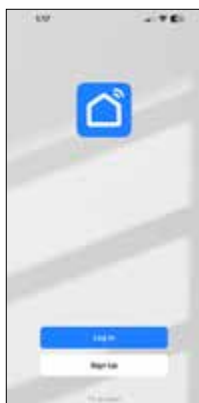

2. Enter your email address, read and agree to the privacy policies and user agreement. Tap “Get Verification code”.



3. A 6-digit verification code will be sent to the registered email address. When prompted, enter the verification code in the app.

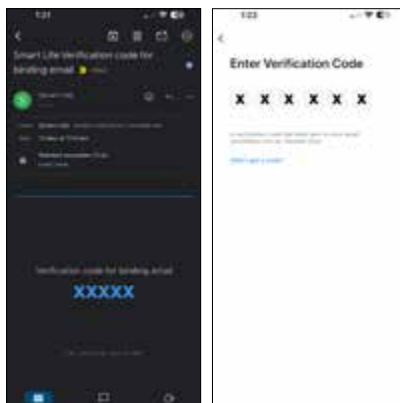



Smart Life App

- Set the desired password. Use 6-20 characters with a mix of letters and numbers.



- Opt in/out allowing the app to collect data related to product usage for maintenance, improvement activities and for personalised recommendations. Tap "Go to App" on the top right corner once done.



- You will now have access to your water heater via the Smart Life App. The default setting for the water heater is Eco mode and set to 60°C. The water heater is ready to use or an alternative mode can be selected. Any changes in the modes or settings can be done remotely provided you have internet connectivity and access to your user account.



Pairing guide

- Once the app is installed and you've signed in, set the water heater to the pairing mode by pressing and holding **M** and **▲** buttons for 3 seconds on the water heater controller.
- Ensure Bluetooth and Wi-Fi is enabled on your phone. Connect the phone to the desired Wi-Fi network that you are intending the water heater to be paired on.



Smart Life App

3. Open the app and tap on the top right corner “+” symbol



5. The app will display the water heaters in pairing mode. Select your heat pump to start the pairing sequence.



4. Click on “Add device”. The phone will now start searching for nearby water heaters that are in pairing mode.



6. When prompted on the app, enter the Wi-Fi password. The app & water heater is in the pairing process & will be added to the app.





Smart Life App

7. A green tick will show on the screen once the heat pump has been added successfully. Tap “Done” to go to the home screen. You can also rename the water heater at this stage by tapping the pen icon.



8. Tap the newly added device to enter the water heater settings & mode selection.



Mode Selection

1. Select your water heater as shown on the user interface.

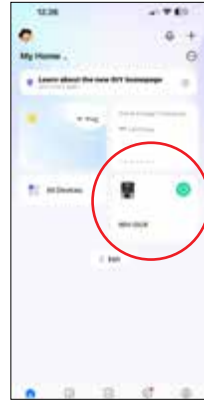

2. Tap on **M** button to select the desired mode. See page 10 in this manual for description of modes.





Smart Life App

Setting the Holiday Mode

The holiday mode is defaulted to 7 days when enabled. To customise:

- o Select holiday mode from the list when shown under the **(M)** button
- o Tap on “Check Status” and scroll down all the way to the bottom

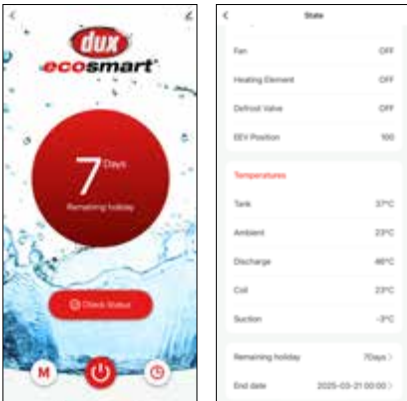

- o Tap on “Remaining holiday” to select the number of days. Variable from 2 min days to max 199 days.

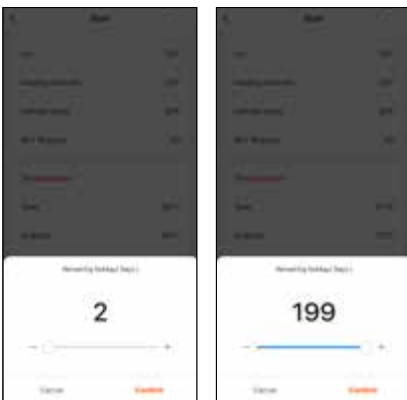

- o Alternatively tap on “End date” to open up the calendar to choose a date to finish the holiday mode.

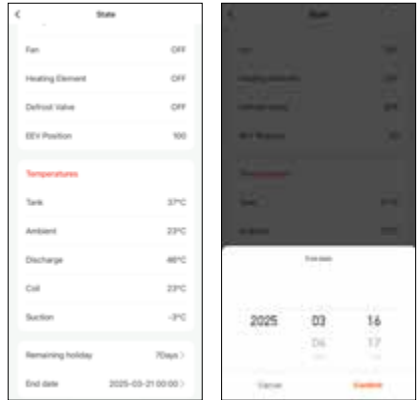

Note: Holiday mode has been designed to start heating the stored water 1 day before the actual return date so that the stored water is hot on your return.

Eg: If the holiday mode is showing the end date as 2025-03-21 10:00, this means the water heater will start heating a day earlier on the 20th March. Ensure the end date displayed is the day you're returning home from holidays so you have hot water on your return and avoid any unnecessary heating.



Smart Life App

Setting the Schedule/Timer

1. Select your water heater as shown on the user interface.

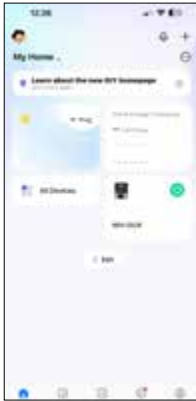

2. Tap on the clock icon on the bottom right corner to enter the Schedule/Timer setting.

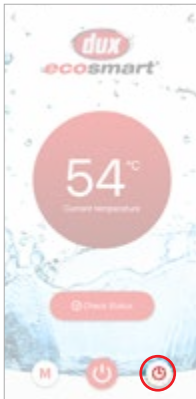

3. Tap “Add” to setup a timer.



4. You can set the water heater to turn ON or OFF at the required time. This can be changed by tapping the ON/OFF button at the bottom of the menu. Select the desired option. The selected option will show with a tick mark next to it. Ensure you select AM and PM accordingly.





Smart Life App

5. You can choose to have this timer active only once or repeat it on certain days of the week or all days of the week. Tap on "Repeat" and select days you want to repeat the timer.

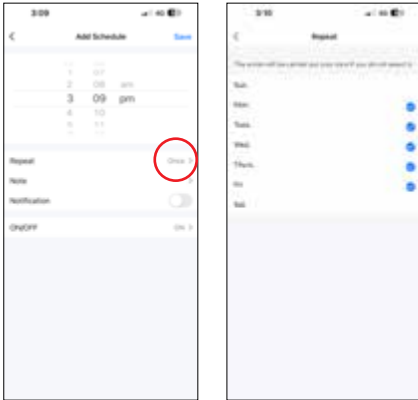

7. You have the option to enable the timer notification so you can be advised that the timer has executed. To enable notification, tap on the notification toggle button.

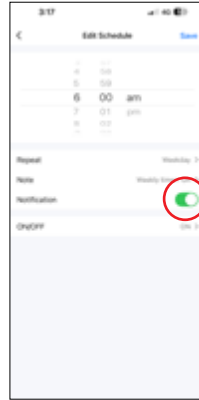

6. You can also create a note for each timer to have a name or description. This will help in identifying the timer details from the schedule home page.



8. Once you have all your preferred timers it will be visible on the schedule summary page. You can enable or disable these timers by tapping on the toggle switch.

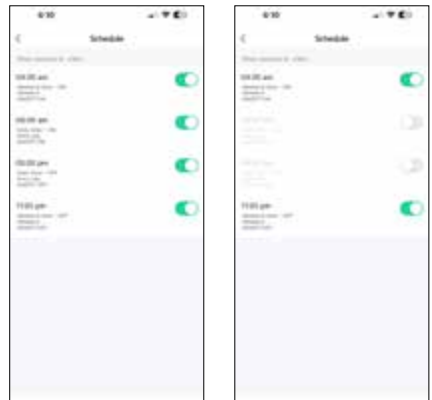



Principle of Operation

Principle of Operation:

A heat pump storage water heater works in a similar way to a reverse cycle air conditioner. Heat is extracted from the outside air and transferred to the water in the storage tank. It does not need to be located in direct sunlight to work.

A heat pump storage water heater can efficiently produce hot water on cloudy and overcast days as well as during the night.

The length of time that the water heater will operate each day will vary depending on the amount of hot water being used and the ambient temperature and humidity.

Generally, the water heater will run longer in winter and at night when the air is cooler due to less heat energy in the air to absorb.

The controller monitors the water temperature and the ambient air temperature. Providing the ambient conditions are suitable, when the water temperature drops, the controller starts the heat pump module to begin heating the water.

Freeze Protection

The water heater is equipped with an active-defrost function which automatically melts ice formed on the evaporator coil during cold ambient conditions.

The water heater also has an anti-freeze function which prevents the water in the tank from icing up during vacation mode.

Damage caused by freezing is not covered by the warranty when the water heater is not connected to power.

WARNING: Power must be available to the water heater at all times for the anti-freeze function to work.

Temperature Settings

The maximum recommended thermostat setting for the water heater is 60°C.

The thermostat settings for the heating element is factory set and must not be changed.

Adjustment of the thermostat for the electric heating element may lead to incorrect operation of the heat pump system.



System Maintenance

Regular servicing will help to extend the life of the water heater, and keep it operating safely and efficiently.

Your water heater warranty is not conditional on completing the regular servicing recommended in this manual.

The conditions applying to your water heater warranty are set out on page 32 of this manual.

Six Month Service:

This service may be carried out by the owner.

1. Stand clear of the Pressure & Temperature Relief (PTR) Valve drain pipe outlet.
2. Open the PTR Valve for approximately 10 seconds by lifting the easing lever on the valve. Confirm water discharges to waste through the drain pipe.
3. Lower the easing lever gently and check it closes correctly.
4. Repeat the above process for the expansion control valve (if installed).
5. Check that the grill on top of the water heater and the louvres are free of debris or other obstructions.

Other than this, personally inspecting or servicing any part of the water heater is not recommended.

Five Year Service:

This service should only be carried out by a licensed tradesperson.

In locations where the water has Total Dissolved Solids (TDS) exceeding 600mg/L, this service is recommended every 3 years.

This service should include the following:

- Replace the PTR Valve.
- Replace both anodes.
- Inspect and flush the expansion control valve (if installed).
- Clean any debris or residue from the condensate gutter and confirm that the condensate drain line is clear.
- Clean any dust or build up from the evaporator and louvres.
- Clean the fan blades and grill.

Drain and flush the water heater.

Replacement parts are available from your local Dux supplier.



System Maintenance

Anode Replacement:

The water heater is equipped with two anode rods.

Follow these steps to replace the anode rods;

1. Ensure that any electrical supply to the water heater is disconnected.
2. Close the isolating valve on the cold-water inlet and release any pressure in the water heater by lifting the lever on the PTR valve.
3. Remove the front cover holding the controller, by removing the screws holding it against the case and pulling it down while simultaneously lifting the bottom of the cover away from the heater. Leave it hanging. Please be careful not to disconnect the wiring connections.
4. Remove the grills on both sides by removing the 2 screws on the top of each grill and pulling the grill out while simultaneously lifting it to disengage the bottom tabs.
5. Disconnect the fan connector and remove the fan by unclipping the Click-fit connections at the 4 corners.
Unclip the ambient sensor attached on the top enclosure near the evaporator coil and push it back into the enclosure.
Remove the 6 screws (3 on each side) holding the top enclosure and slide it up to disengage from the evaporator coil.
6. Remove the 2 anodes using a 1-1/16" socket.
7. Install the new anodes and tighten.
8. Open the cold-water isolating valve and ensure that there is no water leak from the anode connection.
9. Re-install the top enclosure. Ensure that wires are not pinched when doing so. Ensure that the ambient sensor is clipped back into place.
10. Clip the fan back on the top enclosure and attach the connector.
11. Re-install the grills.
12. Re-install the front cover. Ensure that wires are not pinched when doing so.
13. Turn on the electricity supply to the water heater.

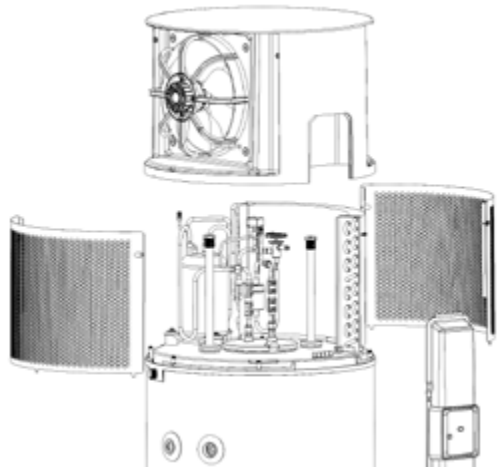



Considering a Service Call?

Although there are no user serviceable components in the water heater, the information contained in this section may enable you to avoid the cost of a service call.

Please do not remove any covers or attempt to make any adjustments.

Water Discharge from Condensation Drain Line:

Water may be expected to drain from the Condensate Drain Line when the water heater is operating. This is similar to the condensation produced by an air conditioner. The amount of condensation produced will depend on ambient conditions such as temperature and humidity.

No Hot Water:

Ensure the power supply circuit breaker has not “tripped”. If the water heater is connected to a controlled load tariff, ensure this is operating correctly.

Smart Life App connectivity:

To connect to the Smart Life app, your Wi-Fi signal must be able to be received at the water heater location. It is possible that you may require Wi-Fi extenders. Otherwise, the heat pump can be directly controlled via the touch screen controller.

Error Detection using Smart Life App:

Check the Smart Life App to ensure it is in an appropriate heating mode, and / or for any indication of errors.

High Energy Bills or Insufficient Hot Water:

- Often the hot water usage of showers, washing machines and dishwashers can be under estimated. Review these appliances to determine if the daily usage is greater than the capability of the water heater.

- If necessary check the shower flow rates with a bucket, measuring the amount of water used over a period of time. If it is not possible to adjust water usage patterns, an inexpensive flow control valve can easily be fitted to the shower outlet.
- Is the water heater the correct size for the requirements? Sizing details are available from your local Reece branch.
- Check that the grills on the sides of the water heater are free of debris or other obstructions.
- The water heater may take longer to reheat during the night as the air is usually cooler. It is possible that the water heater may not fully recover from a period of heavy usage during the previous day. Consider using the BOOST mode to reheat the water faster.
- Is there a leaking hot water pipe or dripping hot water tap? A small leak can waste a large quantity of hot water. Replace faulty tap washers and arrange for your plumber to rectify any leaking pipe work.
- Is the Pressure & Temperature Relief Valve discharging too much water? See below.

Continuous Trickle of Water from Pressure & Temperature Relief (PTR) Valve:

This is most likely due to a build up of foreign matter. In this case, try gently raising the easing lever on the PTR Valve for a few seconds, then release gently.

This may dislodge a small particle of foreign matter and rectify the fault.



Considering a Service Call?

Water Discharge from PTR Valve:

It is not unusual for a small quantity of water to discharge during the heating of water in the storage tank. The amount of discharge will depend on hot water usage and the size of the storage tank.

As a guide, it will discharge about 2% of the volume of the water heated.

Continuous leakage of water from the PTR Valve may indicate a problem with the water heater. Turn off the water heater and contact Dux After Sales and Service.

If after reviewing the information contained in this section, the problem has not been identified, please contact Dux After Sales and Service.

System Fault Error Codes

Check the Smart Life App to ensure the water heater is in an appropriate heating mode, and for any indication of errors. The App will indicate an error if the water heater has incurred a sensor failure. See table below.

ERROR CODE	FAULT	TROUBLESHOOT
E01	Water tank temperature sensor failure	Contact Customer Service on 1300 365 115 (Australia); 0800 729 389 (New Zealand)
E03	Ambient temperature sensor failure	
E04	Compressor discharge temperature sensor failure	
E05	Suction temperature sensor failure	
E06	Evaporator coil temperature sensor failure	
E07	High compressor discharge temperature. Overheat protection active	

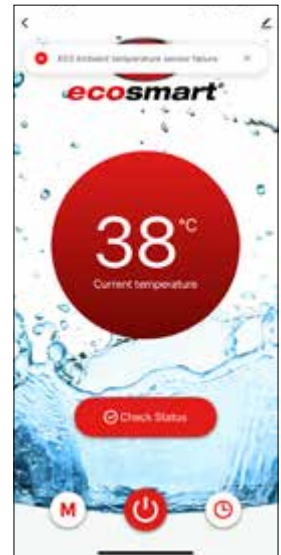



Service & Decommissioning

Checks to the area

Prior to beginning work on systems containing flammable refrigerants, conduct safety checks to ensure that the risk of ignition is minimized.

Work procedure

Work shall be undertaken under a controlled procedure so as to minimize the risk of a flammable gas or vapour being present while the work is being performed.

All maintenance staff and others working in the local area shall be instructed on the nature of work being carried out. Work in confined spaces shall be avoided.

Checking for presence of refrigerant

The area shall be checked with an appropriate refrigerant detector prior to and during work, to ensure the technician is aware of potentially toxic or flammable atmospheres. Ensure that the leak detection equipment being used is suitable for use with all applicable refrigerants, i.e. non-sparking, adequately sealed or intrinsically safe.

Presence of fire extinguisher

If any hot work is to be conducted on the refrigerating equipment or any associated parts, appropriate fire extinguishing equipment shall be available to hand. Have a dry powder or CO₂ fire extinguisher adjacent to the charging area.

No ignition sources

No person carrying out work in relation to a **refrigerating system** which involves exposing any pipe work shall use any sources of ignition in such a manner that it can lead to the risk of fire or explosion.

All possible ignition sources, including cigarette smoking, should be kept sufficiently far away from the site of installation, repairing, removing and disposal, during which refrigerant can possibly be released to the surrounding space. Prior to work taking place, the area around the equipment is to be surveyed to make sure that there are no flammable hazards or ignition risks. "No Smoking" signs shall be displayed.

Ventilated area

Ensure that the area is in the open or that it is adequately ventilated before breaking into the system or conducting any hot work. A degree of ventilation shall continue during the period that the work is carried out.

The ventilation should safely disperse any released refrigerant and preferably expel it externally into the atmosphere.

Checks to the refrigerating equipment

Where electrical components are being changed, they shall be fit for the purpose and to the correct specification. At all times the manufacturer's maintenance and service guidelines shall be followed. If in doubt, consult the manufacturer's technical department for assistance.

Checks to electrical devices

Repair and maintenance to electrical components shall include initial safety checks and component inspection procedures. If a fault exists that could compromise safety, then no electrical supply shall be connected to the circuit until it is satisfactorily dealt with. If the fault cannot be corrected immediately but it is necessary to continue operation, an adequate temporary solution shall be used.



Service & Decommissioning

This shall be reported to the owner of the equipment so all parties are advised.

Initial safety checks shall include:

- that capacitors are discharged: this shall be done in a safe manner to avoid possibility of sparking;
- that no live electrical components and wiring are exposed while charging, recovering or purging the system;
- that there is continuity of earth bonding.

Sealed electrical components

Sealed electrical components shall not be repaired.

Cabling

Check that cabling will not be subject to wear, corrosion, excessive pressure, vibration, sharp edges or any other adverse environmental effects. The check shall also take into account the effects of aging or continual vibration from sources such as compressors or fans.

Detection of flammable refrigerants

Under no circumstances shall potential sources of ignition be used in the searching for or detection of refrigerant leaks. A halide torch (or any other detector using a naked flame) shall not be used.

The following leak detection methods are deemed acceptable for all refrigerant systems.

Electronic leak detectors may be used to detect refrigerant leaks but, in the case of **flammable refrigerants**, the sensitivity can be inadequate, or may need re-calibration.

(Detection equipment shall be calibrated in a refrigerant-free area.) Ensure that the detector is not a potential source of ignition and is suitable for the refrigerant used.

Leak detection equipment shall be set at a percentage of the **LFL** of the refrigerant and shall be calibrated to the refrigerant employed, and the appropriate percentage of gas (25% maximum) is confirmed.

Leak detection fluids are also suitable for use with most refrigerants but the use of detergents containing chlorine shall be avoided as the chlorine can react with the refrigerant and corrode the copper pipework.

NOTE Examples of leak detection methods are

- bubble method,
- fluorescent agent method.

If a leak is suspected, all naked flames shall be removed/extinguished.

If a leakage of refrigerant is found which requires brazing, all of the refrigerant shall be recovered from the system, or isolated (by means of shut-off valves) in a part of the system remote from the leak.

Refrigerant removal and circuit evacuation

For flammable refrigerants it is important that best practice is followed when breaking into the refrigerant circuit to make repairs or for any other purpose since flammability is a consideration. The following procedure shall be adhered to:

- safely remove refrigerant following local and national regulations;
- evacuate;
- purge the circuit with inert gas
- continuously flush with inert gas when using flame to open circuit;
- open the circuit.



Service & Decommissioning

The **refrigerant charge** shall be recovered into the correct recovery cylinders.

Compressed air or oxygen shall not be used for purging refrigerant systems.

NOTE An example of an inert gas is dry nitrogen.

Purging of the refrigerant circuit shall be achieved by breaking the vacuum in the system with inert gas and continuing to fill until the working pressure is achieved, then venting to atmosphere, and finally pulling down to a vacuum. This process shall be repeated until no refrigerant is within the system. The system shall be vented down to atmospheric pressure to enable work to take place.

Ensure that the outlet of the vacuum pump is not close to any potential ignition sources and that ventilation is available.

Charging procedures

In addition to conventional charging procedures, the following requirements shall be followed.

- Ensure that contamination of different refrigerants does not occur when using charging equipment. Hoses or lines shall be as short as possible to minimise the amount of refrigerant contained in them.
- Cylinders shall be kept in an appropriate position according to the instructions.
- Ensure that the refrigerating system is earthed prior to charging the system with refrigerant.
- Label the system when charging is complete (if not already labelled).
- Extreme care shall be taken not to overfill the refrigerating system.

Prior to recharging the system, it shall be pressure-tested with the appropriate purging gas. The system shall be leak tested on completion of charging but prior to commissioning. A follow up leak test shall be carried out prior to leaving the site.

Decommissioning

Before carrying out this procedure, it is essential that the technician is completely familiar with the equipment and all its detail.

It is recommended good practice that all refrigerants are recovered safely. Prior to the task being carried out, an oil and refrigerant sample shall be taken in case analysis is required prior to re-use of recovered refrigerant. It is essential that electrical power is available before the task is commenced.

- 1) Become familiar with the equipment and its operation.
- 2) Isolate system electrically.
- 3) Before attempting the procedure, ensure that:
 - a) mechanical handling equipment is available, if required, for handling refrigerant cylinders;
 - b) all personal protective equipment is available and being used correctly;
 - c) the recovery process is supervised at all times by a competent person;
 - d) recovery equipment and cylinders conform to the appropriate standards.
- 4) Pump down refrigerant system, if possible.
- 5) If a vacuum is not possible, make a manifold so that refrigerant can be removed from various parts of the system.



Service & Decommissioning

- 6) Make sure that the cylinder is situated on the scales before recovery takes place.
- 7) Start the recovery machine and operate in accordance with instructions.
- 8) Do not overfill cylinders (no more than 80% volume liquid charge).
- 9) Do not exceed the maximum working pressure of the cylinder, even temporarily.
- 10) When the cylinders have been filled correctly and the process completed, make sure that the cylinders and the equipment are removed from site promptly and all isolation valves on the equipment are closed off.
- 11) Recovered refrigerant shall not be charged into another **refrigerating system** unless it has been cleaned and checked.

Labelling

Equipment shall be labelled stating that it has been de-commissioned and emptied of refrigerant. The label shall be dated and signed.

Recovery

When removing refrigerant from a system, either for servicing or decommissioning, it is required to follow good practice so that all refrigerants are removed safely.

When transferring refrigerant into cylinders, ensure that only appropriate refrigerant recovery cylinders are employed. Ensure that the correct number of cylinders for holding the total system charge is available.

All cylinders to be used are designated for the recovered refrigerant and labelled for

that refrigerant (i.e. special cylinders for the recovery of refrigerant). Cylinders shall be complete with pressure-relief valve and associated shut-off valves in good working order.

Empty recovery cylinders are evacuated and, if possible, cooled before recovery occurs.

The recovery equipment shall be in good working order with a set of instructions concerning the equipment that is at hand and shall be suitable for the recovery of the **flammable refrigerant**.

Consult manufacturer if in doubt. In addition, a set of calibrated weighing scales shall be available and in good working order. Hoses shall be complete with leak-free disconnect couplings and in good condition.

The recovered refrigerant shall be processed according to local legislation in the correct recovery cylinder, and the relevant waste transfer note arranged. Do not mix refrigerants in recovery units and especially not in cylinders.

If compressors or compressor oils are to be removed, ensure that they have been evacuated to an acceptable level to make certain that flammable refrigerant does not remain within the lubricant. The compressor body shall not be heated by an open flame or other ignition sources to accelerate this process. Draining of oil from a system shall be carried out safely.



Warranty

Ecosmart Heat Pump Water Heater - Warranty Summary:

Your water heater is specified with a warranty as set out in the table below.

The fault must appear within the defined time period, which commences from the date of installation (or manufacturing date of the unit if proof of the date of installation is not available) in order to be covered.

Ecosmart Heat Pump Water Heater Warranty [#]		Tank Warranty [#]	Heat Pump Component ¹ Warranty	Other Components ² Warranty
Single Family Dwelling	Parts	7 years	3 years	1 year
	Labour	3 years	3 years	1 year
All Other Applications	Parts	3 years	1 year	1 year
	Labour	1 year	1 year	1 year

(1) Heat Pump Components include: controller, compressor, condenser, expansion valve, heat exchanger, evaporator and associated pipe work.

(2) Other Components include but are not limited to: sensors, thermostat, PTR valve, electric heating elements, anodes.*Inner Storage Cylinder.

The benefits provided to you by this warranty are in addition to any other rights and remedies available to you under the Australian Consumer Law or the Consumer Guarantees Act 1993 (New Zealand).

#Where an incentive is being applied for under the Victorian Energy Upgrades (VEU) Program, through the Solar Victoria's Solar Home Program or NSW Energy Savings Scheme (ESS), a separate warranty applies. See page 31.

Other Components² Warranty:

Dux Manufacturing Limited ('Dux') warrants against defects in the water heater arising from faulty materials or workmanship. During the period of coverage (as specified in the table above), Dux will repair or replace any specified failed components² free of charge including reasonable labour costs incurred during normal business working hours.

Heat Pump Component¹ Warranty:

Dux warrants against failure of the controller & refrigeration components¹ arising from faulty materials or workmanship (as specified in the table above). During this period of coverage Dux will repair or replace specified failed components¹ free of charge including reasonable labour costs incurred during normal business working hours.

Tank Failure Warranty:

Dux warrants against failure of the storage tank, in accordance with its application (as specified in the table above). Conditions apply. During the period of coverage (as specified in the table above), Dux will repair or replace the tank free of charge including reasonable labour costs incurred during normal business working hours.

Installation and other labour costs are the responsibility of the owner if the water heater is outside the labour warranty period.



Warranty

Victorian Energy Upgrades (VEU) Warranty:

Without limiting the periods shown in the table on page 30, a 5 year product warranty applies where Victorian Energy Efficiency Certificates (VEECs) have been created for an eligible water heater installation activity (activity 1, 3 or 44) when installed from 1st February 2025.

For further details call 1300 365 115. Proof of VEEC assignment is required to be provided at the time of booking the service call.

Solar Victoria's Solar Home Program Warranty:

Without limiting the periods shown in the table on page 30, a 5 year 'Whole of Product' warranty applies where a rebate has been received under Solar Victoria's Solar Homes Program for a water heater installed from 1st July 2023.

The 5 year 'Whole of Product' warranty will also include labour coverage for installations from 1st September 2025.

For further details call 1300 365 115. Rebate proof of receipt is required to be provided at the time of booking the service call.

NSW Energy Savings Scheme (ESS) Warranty:

Without limiting the periods shown in the table on page 30, a warranty against defects covering at least five years from the date of installation, purchase or supply is applicable where NSW Energy Savings Scheme (ESS) Certificates have been created for an eligible water heater installation activity from 1st December 2025.

For further details call 1300 365 115. Proof

that NSW Energy Savings Certificates (ESCs) were created for the heat pump installation are required to be provided at the time of booking the service call.

Warranty Conditions:

The warranty only applies to the water heater itself and the components supplied with the water heater by Dux. The warranty does not cover components supplied by others, including the installer.

Dux may reject a claim under this warranty in its sole discretion if a third party solar diverter is connected to the water heater.

The tank failure warranty does not apply if the water heater has been connected to a water supply where the Total Dissolved Solids (TDS) content is greater than 2500mg/L.

For TDS between 600mg/L and 2500mg/L, a hard water version with Aluminium anodes must be used. Warranty does not apply for heaters with Magnesium anodes when TDS is greater than 600mg/L.

Warranty also does not apply if the Saturation Index (LSI) is less than -1.0 or greater than +0.8. LSI figures stated above are calculated with a water temperature of 80°C.

These warranties do not apply to defects that are a result of, without limitation, the following:

- failure to install the water heater in accordance with the installation instructions or statutory requirements;
- faulty plumbing or water supply including excessive pressure;
- faulty power supply;
- damage caused by freezing is not covered by the warranty when not connected to power;



Warranty

- use of the water heater in a manner contrary to this manual or other instructions provided by Dux;
- alterations or repair of the water heater other than by an accredited and licensed service agent or technician;
- accidental damage or abuse
- where the water heater has been tilted more than 45 degrees from vertical;
- if the water pH is less than 6.5 or greater than 9.5;
- where penetrations damage the heat exchanger coil on the tank, or the inner tank cylinder, warranty will be void.

If the water heater is installed in a position that does not comply with the installation instructions or statutory requirements, then this warranty does not cover major dismantling or removal of cupboards, doors, walls or special equipment and/or excessive labour, at the determination of Dux, to make the water heater accessible for repair or replacement.

Where the Dux water heater is located outside the metropolitan area of a capital city and is more than 100km from a Dux office or Dux agent, the Owner will be responsible under the warranty for paying the costs of transporting the water heater and or any component in the water heater to and from an approved Dux agent or Dux office (including any insurance associated with that transport), or paying the travelling time of an approved Dux agent to and from the owners premises.

Commencement of Warranty:

The warranty period commences from the date of installation of the water heater. Where proof of the date of installation is not

available, the warranty period commences on the date of manufacture of the water heater. This is shown on the compliance plate on the outside of the water heater.

The replacement of the water heater, or a component of it, under this warranty does not change the warranty commencement date. The original commencement date continues to apply.

Exclusion and Limitation of Liability:

In addition to any other provisions set out in this document and to the maximum extent permitted by any applicable law or regulation, Dux will not be liable for any claim:

1. for consequential loss to any property arising directly or indirectly out of or connected to the installation of the water heater. This includes but is not limited to furnishings, carpets, foundations, housing effects and buildings.
2. for any direct or indirect economic or financial loss of any nature.
3. arising out of or connected to a water heater that has been uninstalled, resold or moved from its original installation location.
4. arising out of or connected to any misuse, or other use, installation or maintenance that is not in accordance with the procedures and requirements set out in this document.

To the extent permitted by law the liability of Dux shall be limited to the cost of the repair or replacement of the water heater.



Warranty

The Australian Consumer Law (“ACL”):

Our goods come with guarantees that cannot be excluded under the Australian Consumer Law. You are entitled to a replacement or refund for a major failure and compensation for any other reasonably foreseeable loss or damage. You are also entitled to have the goods repaired or replaced if the goods fail to be of acceptable quality and the failure does not amount to a major failure.

If Dux fails to meet a guarantee under the ACL, your remedy for such failure may be limited to any one or more of the following:

- replacement of the water heater;
- repair of the water heater;
- refunding the cost of the water heater;
- payment of the reasonable costs of having the water heater repaired;
- payment in respect of the reduced value of the water heater.

The Consumer Guarantees Act 1993 (New Zealand):

Our goods come with guarantees that cannot be excluded under the Consumer Guarantees Act 1993 (New Zealand). If the goods fail to comply with the applicable guarantees set out under the Consumer Guarantees Act 1993 (New Zealand) being the guarantee as to acceptable quality, the guarantee as to correspondence with description or the guarantee as to repair and parts, or if the goods fail to comply with any express guarantee given by Dux, then you are entitled to a replacement or refund and for compensation for any other reasonably foreseeable loss or damage.

How to Make a Warranty Claim:

Warranty claims can be placed by completing the following steps:

- Contact Dux on one of the numbers listed below.
- Select the “Service” option followed by the “Hot Water” option.
- Provide the serial number and model number of the water heater. This can be found on the compliance plate on the outside of the water heater.
- Provide your full name, address & contact number.
- Provide proof of date of installation for warranty to commence from that date, rather than from the date of manufacture. See Commencement of Warranty on page 32.

Please note, if the defect or fault is not covered by the warranty or guarantee, you will be responsible for the costs incurred by the service agent or technician.

Dux service calls can only be scheduled during business hours (AEST) Monday to Friday and are not available on weekends & public holidays.

Contact Details:

Dux Manufacturing Limited
Lackey Road, Moss Vale, NSW, 2577,
Australia

1300 365 115 (Australia)

0800 729 389 (New Zealand)

Email: duxaftersales@dux.com.au



For advice, repairs and service, call:

1300 365 115 (Australia)

0800 729 389 (New Zealand)

Please Register Your Water Heater



Please take a moment to fill out your details for warranty registration at:

www.dux.com.au/warranty

or use your smartphone to scan this code:

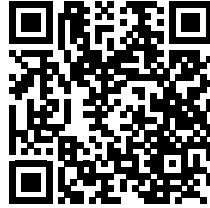

This will ensure all your current details are registered with us for prompt warranty service if required.

To view our privacy policy please visit <http://www.dux.com.au/p/privacy>

Date of Installation:

Installer's Name:

Installer's Company:

Installer's Licence No:

Installer's Signature:

Serial Number



H4149